



US Army Corps  
of Engineers  
Seattle District

# Public Notice of Application for Permit

**Regulatory Branch**  
**Post Office Box 3755**  
**Seattle, Washington 98124-3755**  
**Telephone (206) 258-1371**  
**ATTN: Debbie Knaub, Project Manager**

**Public Notice Date: January 12, 2015**  
**Expiration Date: February 11, 2015**

**Reference: NWS-2014-815**  
**and NWS-2014-1152**  
**Name: Fahey, Kelly**

---

Interested parties are hereby notified that an application has been received for a Department of the Army permit in accordance with Section 10 of the Rivers and Harbors Act of 1899, for certain work described below and shown on the two sets of enclosed drawings dated July 16, 2014 (NWS-2014-1152) ( parcel 28-21-16-770-085), and July 17, 2014 (NWS-2014-815) (parcel 21-21-16-770-090).

APPLICANT: Kelly Fahey  
17901 – 41<sup>st</sup> Place West  
Lynnwood, Washington 98037  
Telephone: (206) 730-1085

AGENT: Grette Associates LLC  
151 South Worthen Street, Suite 101  
Wenatchee, Washington 98801  
ATTN: Ms. Anne Hessburg  
Telephone: (509) 663-6300

LOCATION: In Lake Chelan, near Manson, Chelan County, Washington.

WORK: Construct two 450-square-foot piers and install two boat lifts and two mooring buoys on two adjacent properties.

PURPOSE: Lake access and boat moorage for two adjacent properties.

MITIGATION: For each pier, 450 square feet of large woody material will be placed just landward of 1,079-foot elevation, for a total of 900 square feet of large woody material.

ENDANGERED SPECIES: The Endangered Species Act (ESA) requires federal agencies to consult with the National Marine Fisheries Service (NMFS) and/or U.S. Fish and Wildlife Service (USFWS) pursuant to Section 7 of ESA on all actions that may affect a species listed (or proposed for listing) under the ESA as threatened or endangered or any designated critical habitat.

The U.S. Army Corps of Engineers (Corps) has determined that authorized in the South Lake Chelan Action Area (SLCAA) will have no effect on Columbia River bull trout. No ESA section 7 consultation is required.

**ESSENTIAL FISH HABITAT:** The Magnuson-Stevens Fishery Conservation and Management Act, as amended by the Sustainable Fisheries Act of 1996, requires all Federal agencies to consult with the NMFS on all actions, or proposed actions, permitted, funded, or undertaken by the agency, that may adversely affect Essential Fish Habitat (EFH). There is no area of EFH in Lake Chelan. The Corps has determined that the proposed action will not adversely affect designated EFH for federally managed fisheries in Washington waters. No further EFH consultation is necessary.

**CULTURAL RESOURCES:** The Corps has reviewed the latest published version of the National Register of Historic Places, lists of properties determined eligible and other sources of information. There are no recorded historic properties within the permit area. The proposed work is of such a limited nature and extent that little likelihood exists for the project to impinge upon an unrecorded historic property.

The Corps invites responses to this public notice from Native American Tribes or tribal governments; Federal, State, and local agencies; historical and archeological societies; and other parties likely to have knowledge of or concerns regarding historic properties and sites of religious and cultural significance at or near the project area. After receipt of comments from this public notice, the Corps will evaluate potential impacts and consult with the State Historic Preservation Officer and Native American Tribes in accordance with Section 106 of the National Historic Preservation Act, as appropriate.

**PUBLIC HEARING:** Any person may request, in writing, within the comment period specified in this notice, that a public hearing be held to consider this application. Requests for public hearings shall state, with particularity, the reasons for holding a public hearing.

**EVALUATION:** The decision whether to issue a permit will be based on an evaluation of the probable impacts, including cumulative impacts, of the proposed activity on the public interest. That decision will reflect the national concern for both protection and utilization of important resources. The benefits, which reasonably may be expected to accrue from the proposal, must be balanced against its reasonably foreseeable detriments. All factors which may be relevant to the proposal will be considered, including the cumulative effects thereof; among those are conservation, economics, aesthetics, general environmental concerns, wetlands, historic properties, fish and wildlife values, flood hazards, floodplain values, land use, navigation, shoreline erosion and accretion, recreation, water supply and conservation, water quality, energy needs, safety, food and fiber production, mineral needs, considerations of property ownership, and, in general, the needs and welfare of the people.

The U.S. Army Corps of Engineers is soliciting comments from the public; Native American Nations or tribal governments; Federal, State, and local agencies and officials; and other interested parties in order to consider and evaluate the impacts of this activity. Any comments received will be considered by the Corps to determine whether to issue, modify, condition or deny a permit for the work. To make this decision, comments are used to assess impacts on endangered species, historic properties, water quality, general environmental effects, and the other public interest factors listed above. Comments are used in the preparation of an Environmental Assessment and/or an Environmental Impact Statement pursuant to the National Environmental Policy Act. Comments are also used to determine the need for a public hearing and to determine the overall public interest of the activity.

**COMMENT AND REVIEW PERIOD:** Conventional mail or e-mail comments on this public notice will be accepted and made part of the record and will be considered in determining whether it would be in the public interest to authorize this proposal. In order to be accepted, e-mail comments must originate from the author's e-mail account and must include on the subject line of the e-mail message the permit applicant's name and reference number as shown below. All e-mail comments should be sent to [deborah.j.knaub@usace.army.mil](mailto:deborah.j.knaub@usace.army.mil). Conventional mail comments should be sent U.S. Army Corps of Engineers, Regulatory Branch, P.O. Box 3755, Seattle, Washington 98124-3755. Either conventional mail or e-mail comments must include the permit

NWS-2014-815 and NWS-2014-1152

applicant's name and reference number, as shown below, and the commentator's name, address, and phone number. All comments received will become part of the administrative record and are subject to public release under the Freedom of Information Act including any personally identifiable information such as names, phone numbers, and addresses. All comments whether conventional mail or e-mail must reach this office, no later than the expiration date of this public notice to ensure consideration. Please include the following name and reference number:

Fahey, Kelly, NWS-2014-815 and NWS-2014-1152

Encl: Figures (7 pages for each project for a total of 14 pages)



PURPOSE: CONSTRUCTION OF A SINGLE USE PIER, STAIRS, BOATLIFT & BUOY

ADJACENT PROPERTY OWNERS:

① ZULUAGA CHARITABLE UNITRUST  
538 HYACINTH ROAD  
MANSON, WA 98831

② KELLY FAHEY  
17901 - 41ST PLACE W  
LYNNWOOD, WA 98037

VICINITY MAP



LAT: 47.9248 N; LONG: -120.1977 W

IN: LAKE CHELAN  
KUTIL PLACE - 090  
MANSON, WA 98831

COUNTY OF: CHELAN  
STATE: WA  
APPLICATION BY: KELLY FAHEY

SHEET NO. 1 OF 7 DATE: 7/17/14

LAKE CHELAN

1079'

DOCK

OHWM/1100'

69'

HOUSE

DRIVEWAY

KUTIL PLACE

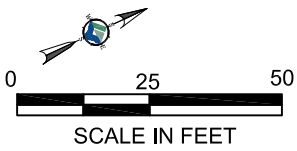

PURPOSE: CONSTRUCTION OF A SINGLE USE PIER, STAIRS, BOATLIFT & BUOY

ADJACENT PROPERTY OWNERS:

① ZULUAGA CHARITABLE UNITRUST  
538 HYACINTH ROAD  
MANSON, WA 98831

② KELLY FAHEY  
17901 - 41ST PLACE W  
LYNNWOOD, WA 98037

EXISTING CONDITIONS



IN: LAKE CHELAN  
KUTIL PLACE - 090  
MANSON, WA 98831

COUNTY OF: CHELAN  
STATE: WA  
APPLICATION BY: KELLY FAHEY

SHEET NO. 2 OF 7 DATE: 7/17/14

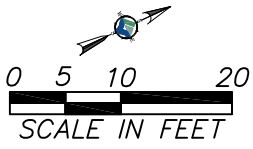
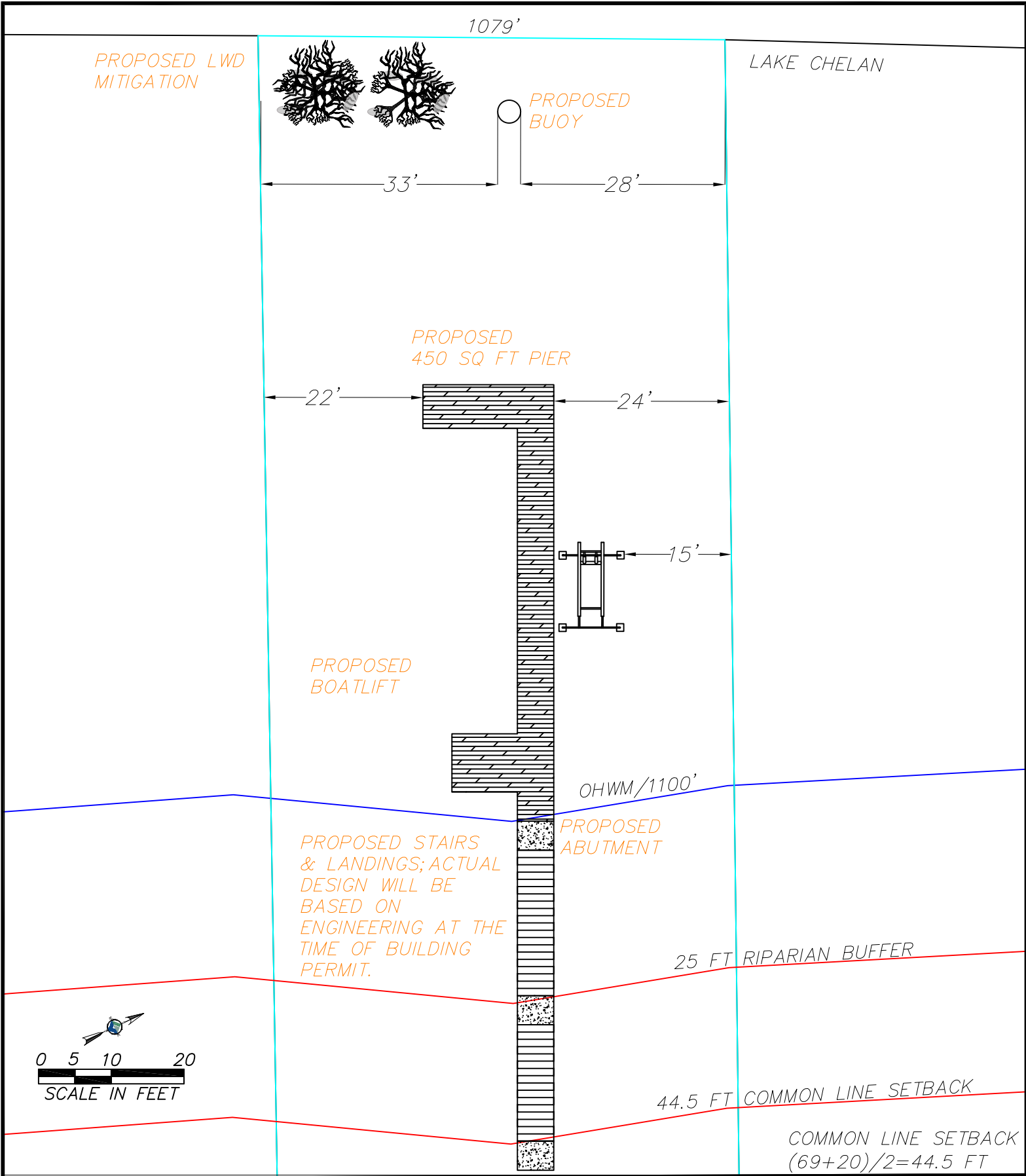

PURPOSE: CONSTRUCTION OF A SINGLE USE PIER, STAIRS, BOATLIFT & BUOY

ADJACENT PROPERTY OWNERS:

① ZULUAGA CHARITABLE UNITRUST  
538 HYACINTH ROAD  
MANSON, WA 98831

② KELLY FAHEY  
17901 - 41ST PLACE W  
LYNNWOOD, WA 98037

## SITE PLAN



**Grette Associates** LLC  
ENVIRONMENTAL CONSULTANTS

IN: LAKE CHELAN  
KUTIL PLACE - 090  
MANSON, WA 98831

COUNTY OF: CHELAN  
STATE: WA  
APPLICATION BY: KELLY FAHEY

SHEET NO. 3 OF 7 DATE: 7/17/14

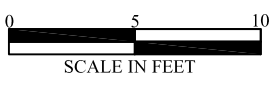
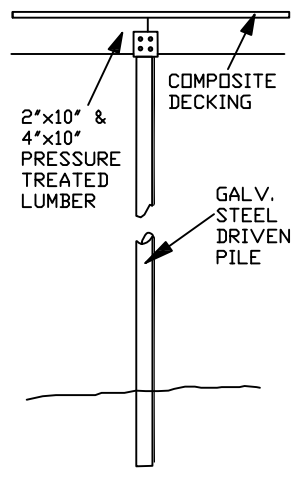
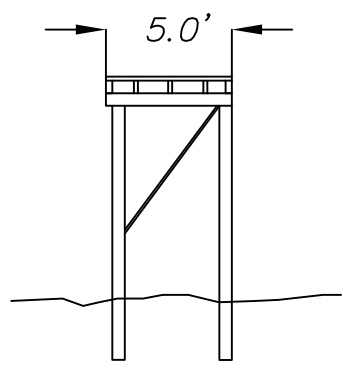
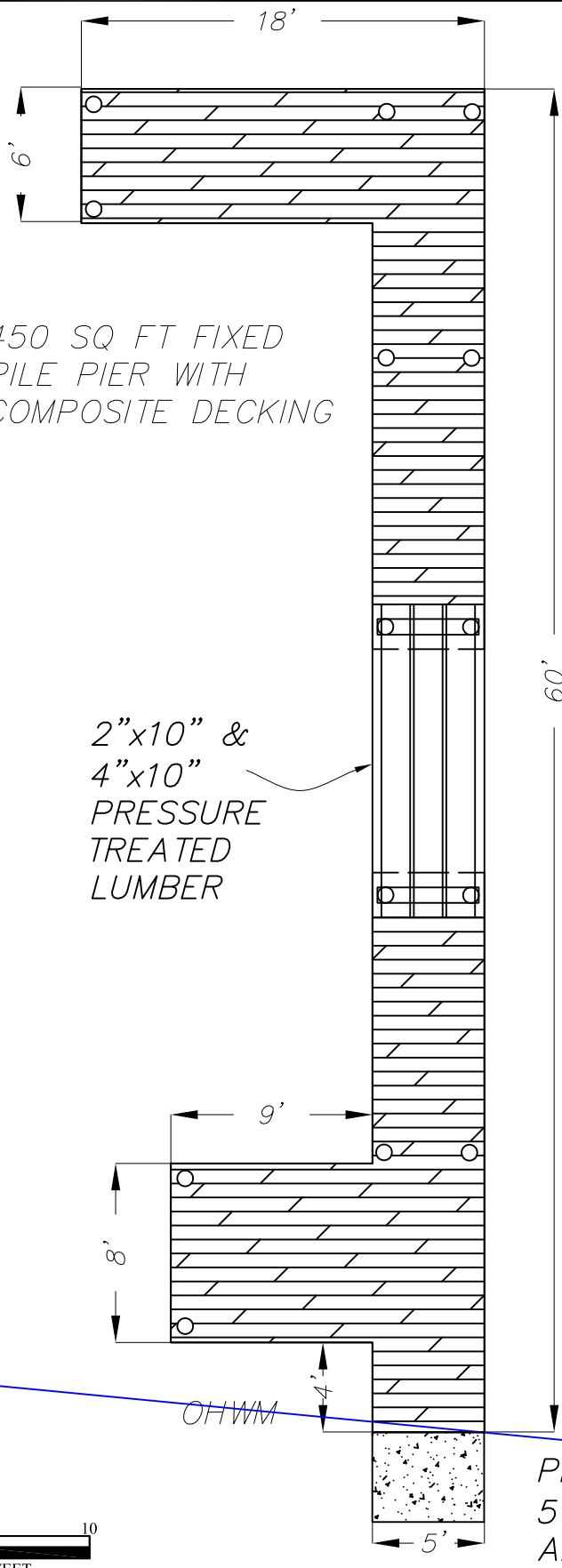

PROPOSED  
5'X4'X4'  
ABUTMENT

PURPOSE: CONSTRUCTION OF A SINGLE USE PIER,  
STAIRS, BOATLIFT & BUOY

ADJACENT PROPERTY OWNERS:

① ZULUAGA CHARITABLE UNITRUST  
538 HYACINTH ROAD  
MANSON, WA 98831

② KELLY FAHEY  
17901 - 41ST PLACE W  
LYNNWOOD, WA 98037

**PIER PLAN**



**Grette Associates**<sup>LLC</sup>  
ENVIRONMENTAL CONSULTANTS

IN: LAKE CHELAN  
KUTIL PLACE - 090  
MANSON, WA 98831

COUNTY OF: CHELAN  
STATE: WA  
APPLICATION BY: KELLY FAHEY

SHEET NO. 4 OF 7 DATE: 7/17/14

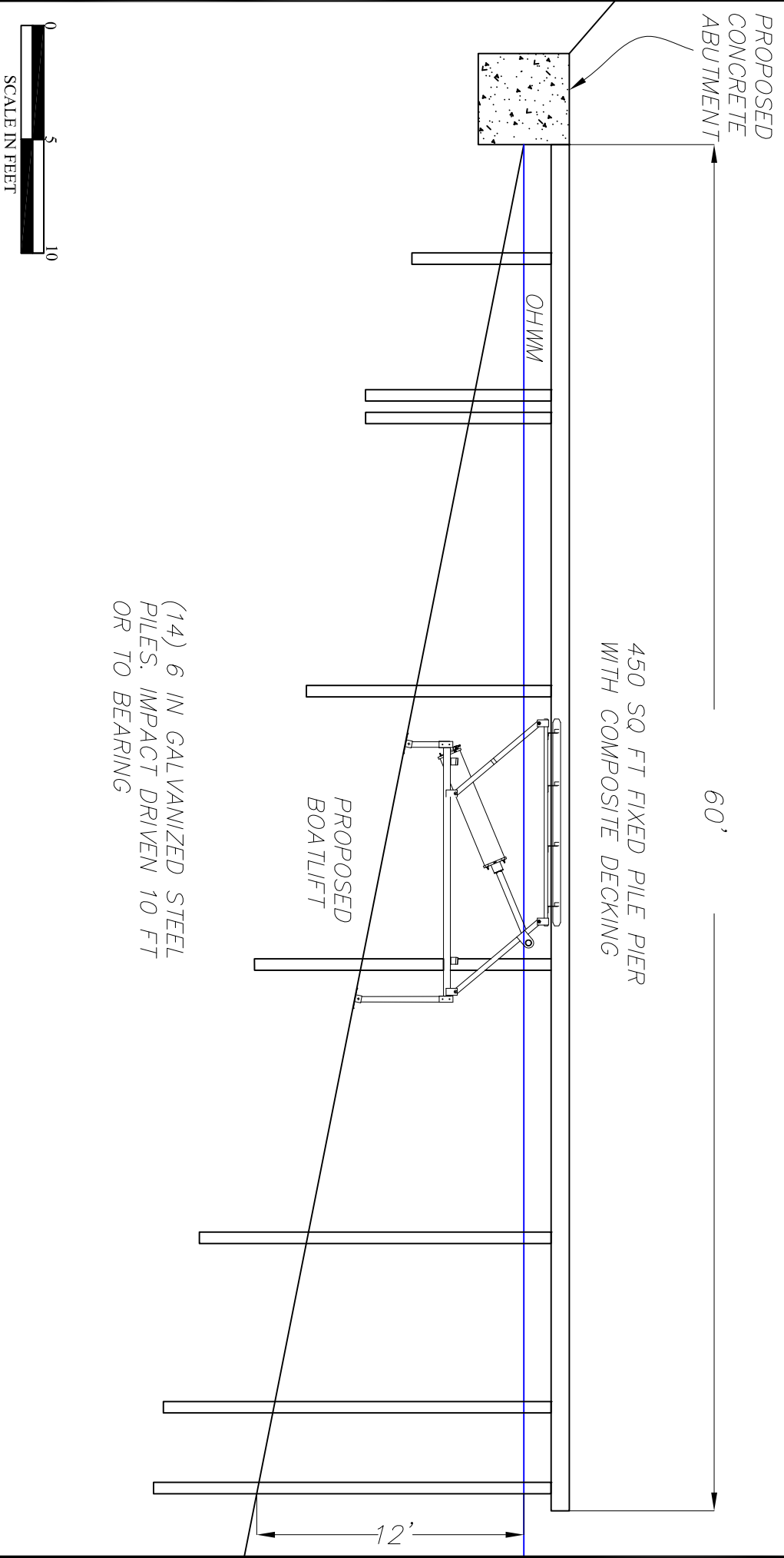

**CROSS SECTION**

PURPOSE: CONSTRUCTION OF A SINGLE USE PIER, STAIRS, BOATLIFT & BUOY

ADJACENT PROPERTY OWNERS:  
 ① ZULUAGA CHARITABLE UNITRUST  
 538 HYACINTH ROAD  
 MANSON, WA 98831

② KELLY FAHEY  
 17901 - 41ST PLACE W  
 LYNNWOOD, WA 98037



IN: LAKE CHELAN  
 KUTILL PLACE - 090  
 MANSON, WA 98831

COUNTY OF: CHELAN  
 STATE: WA  
 APPLICATION BY: KELLY FAHEY

SHEET NO. 5 OF 7 DATE: 2/17/14



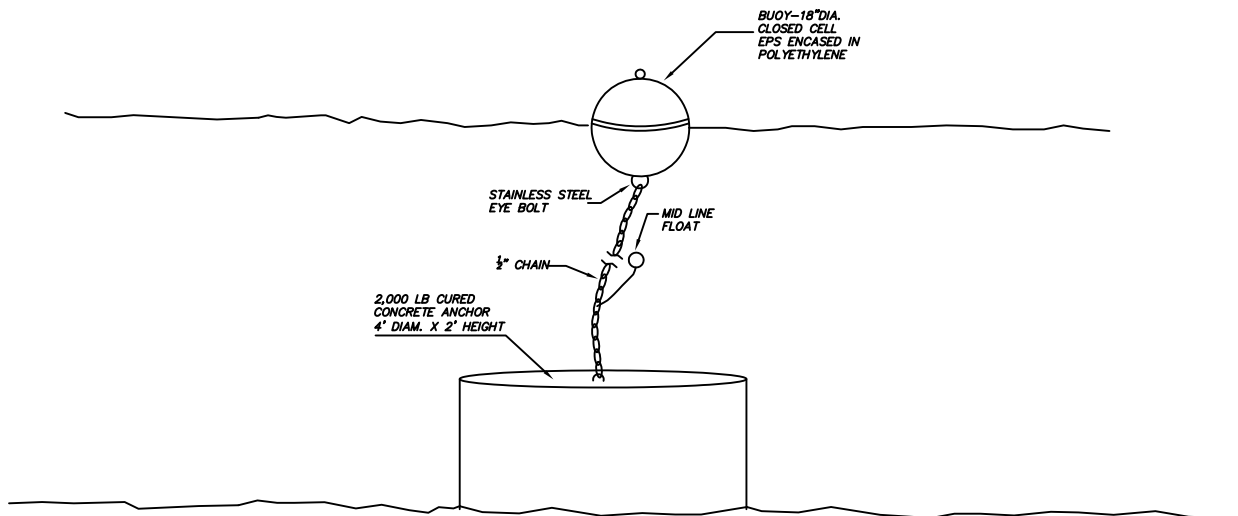
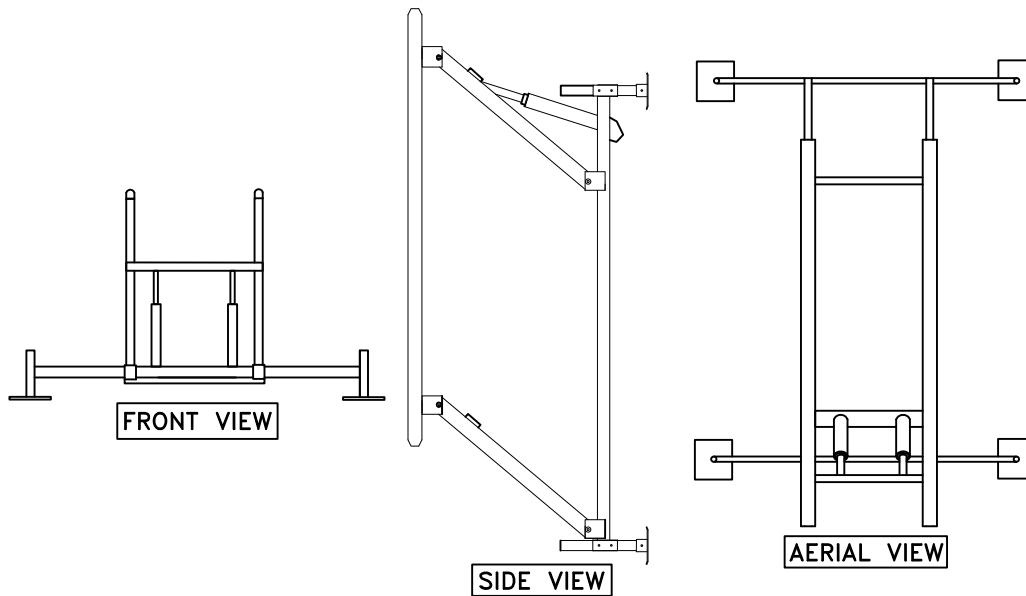
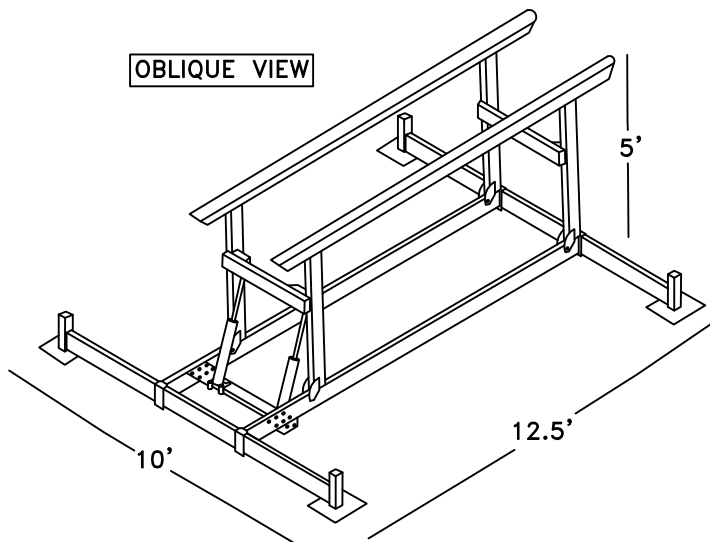

PURPOSE: CONSTRUCTION OF A SINGLE USE PIER, STAIRS, BOATLIFT & BUOY

ADJACENT PROPERTY OWNERS:

① ZULUAGA CHARITABLE UNITRUST  
538 HYACINTH ROAD  
MANSON, WA 98831

② KELLY FAHEY  
17901 - 41ST PLACE W  
LYNNWOOD, WA 98037

BOATLIFT/BUOY DETAILS



IN: LAKE CHELAN  
KUTIL PLACE - 090  
MANSON, WA 98831

COUNTY OF: CHELAN  
STATE: WA  
APPLICATION BY: KELLY FAHEY

SHEET NO. 6 OF 7 DATE: 7/17/14



PHOTOGRAPH OF ACTUAL LWD IN LAKE CHELAN

LWD COVER STRUCTURE

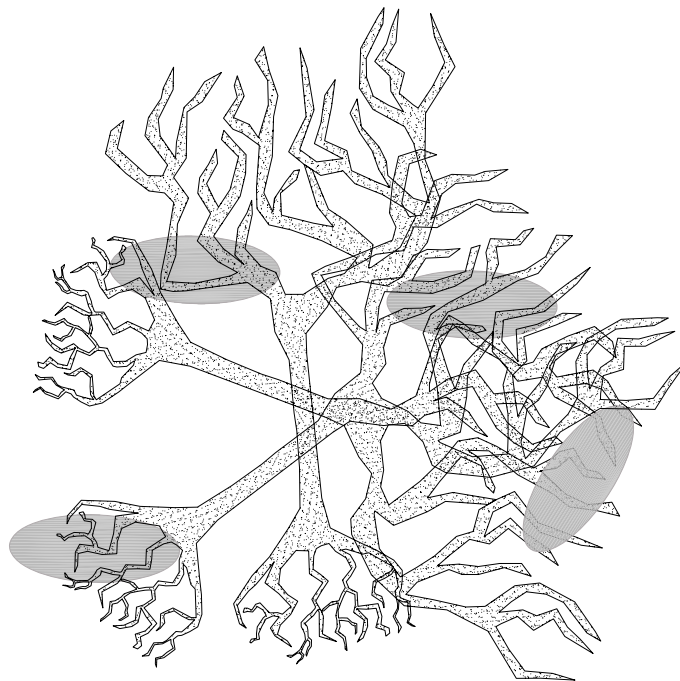

ONE GROUP OF 3 WHOLE MATURE FRUIT TREES WITH LIMBS AND ROOTWADS ATTACHED

ONE GROUP OF 4 WHOLE MATURE FRUIT TREES WITH LIMBS AND ROOTWADS ATTACHED

TREES CABLED TOGETHER AND ANCHORED WITH LARGE ROCK OR SCREW ANCHORS. SEVEN TREES TOTAL.

PURPOSE: CONSTRUCTION OF A SINGLE USE PIER STAIRS, BOATLIFT & BUOY

ADJACENT PROPERTY OWNERS:

① ZULUAGA CHARITABLE UNITRUST  
538 HYACINTH ROAD  
MANSON, WA 98831

② KELLY FAHEY  
17901 - 41ST PLACE W  
LYNNWOOD, WA 98037

MITIGATION



IN: LAKE CHELAN  
KUTIL PLACE - 090  
MANSON, WA 98831

COUNTY OF: CHELAN  
STATE: WA  
APPLICATION BY: KELLY FAHEY

SHEET NO. 7 OF 7 DATE: 7/17/14



PURPOSE: CONSTRUCTION OF A SINGLE USE PIER,  
STAIRS, BOATLIFT & BUOY

ADJACENT PROPERTY OWNERS:

- ① THOMAS UTIGARD  
40 JENNINGS STREET  
WENATCHEE, WA 98801
- ② KELLY FAHEY  
17901 - 41ST PLACE W  
LYNNWOOD, WA 98037

VICINITY MAP



LAT: 47.9247 N; LONG: -120.1978 W

IN: LAKE CHELAN  
KUTIL PLACE - 085  
MANSON, WA 98831

COUNTY OF: CHELAN  
STATE: WA  
APPLICATION BY: KELLY FAHEY

SHEET NO. 1 OF 7 DATE: 7/16/14

LAKE CHELAN

1079'

DOCK

OHWM/1100'

VACANT LOT

VACANT LOT

VACANT LOT

DRIVEWAY

HOUSE

KUTIL PLACE

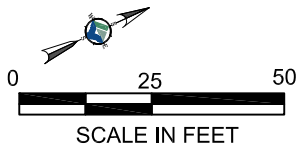

PURPOSE: CONSTRUCTION OF A SINGLE USE PIER, STAIRS, BOATLIFT & BUOY

ADJACENT PROPERTY OWNERS:

- ① THOMAS UTIGARD  
40 JENNINGS STREET  
WENATCHEE, WA 98801
- ② KELLY FAHEY  
17901 - 41ST PLACE W  
LYNNWOOD, WA 98037

EXISTING CONDITIONS



IN: LAKE CHELAN  
KUTIL PLACE - 085  
MANSON, WA 98831

COUNTY OF: CHELAN  
STATE: WA  
APPLICATION BY: KELLY FAHEY

SHEET NO. 2 OF 7 DATE: 7/16/14

1079'

PROPOSED LWD MITIGATION

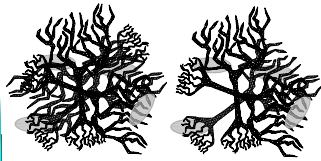

PROPOSED BUOY

LAKE CHELAN

32'

27'

PROPOSED 450 SQ FT PIER

23'

20'

14'

PROPOSED BOATLIFT

OHWM/1100'

PROPOSED STAIRS & LANDINGS; ACTUAL DESIGN WILL BE BASED ON ENGINEERING AT THE TIME OF BUILDING PERMIT.

PROPOSED ABUTMENT

20 FT COMMON LINE SETBACK

25 FT RIPARIAN BUFFER

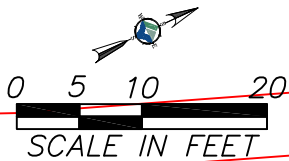

PURPOSE: CONSTRUCTION OF A SINGLE USE PIER, STAIRS, BOATLIFT & BUOY

ADJACENT PROPERTY OWNERS:

① THOMAS UTIGARD  
40 JENNINGS STREET  
WENATCHEE, WA 98801

② KELLY FAHEY  
17901 - 41ST PLACE W  
LYNNWOOD, WA 98037

### SITE PLAN



IN: LAKE CHELAN  
KUTIL PLACE - 085  
MANSON, WA 98831

COUNTY OF: CHELAN  
STATE: WA  
APPLICATION BY: KELLY FAHEY

SHEET NO. 3 OF 7 DATE: 7/16/14

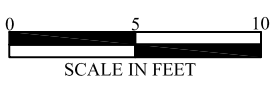
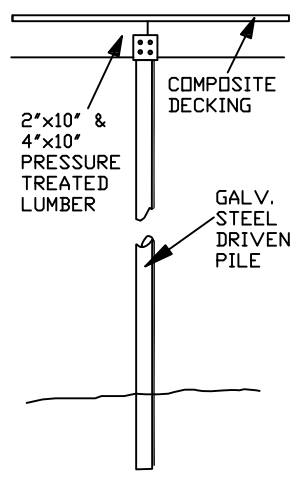
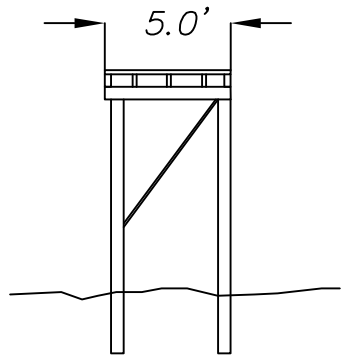
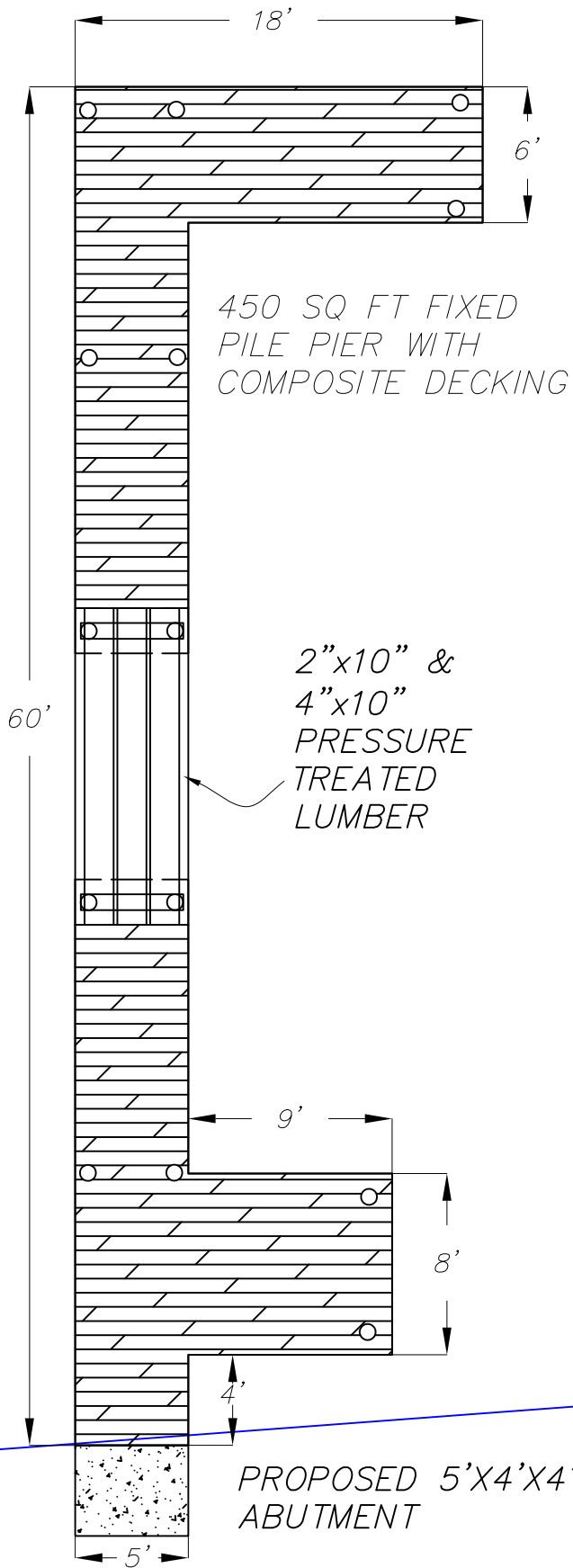

PURPOSE: CONSTRUCTION OF A SINGLE USE PIER,  
STAIRS, BOATLIFT & BUOY

ADJACENT PROPERTY OWNERS:

① THOMAS UTIGARD  
40 JENNINGS STREET  
WENATCHEE, WA 98801

② KELLY FAHEY  
17901 - 41ST PLACE W  
LYNNWOOD, WA 98037

### PIER PLAN

**Grette Associates**<sup>LLC</sup>  
ENVIRONMENTAL CONSULTANTS

IN: LAKE CHELAN  
KUTIL PLACE - 085  
MANSON, WA 98831

COUNTY OF: CHELAN  
STATE: WA  
APPLICATION BY: KELLY FAHEY

SHEET NO. 4 OF 7 DATE: 7/16/14

PROPOSED  
CONCRETE  
ABUTMENT

60'

450 SQ FT FIXED PILE PIER  
WITH COMPOSITE DECKING

OHWM

PROPOSED  
BOATLIFT

(14) 6 IN GALVANIZED STEEL  
PILES. IMPACT DRIVEN 10 FT  
OR TO BEARING

12'



PURPOSE: CONSTRUCTION OF A SINGLE USE PIER,  
STAIRS, BOATLIFT & BUOY

ADJACENT PROPERTY OWNERS:

- ① THOMAS UTIGARD  
40 JENNINGS STREET  
WENATCHEE, WA 98801
- ② KELLY FAHEY  
17901 - 41ST PLACE W  
LYNNWOOD, WA 98037

CROSS SECTION



IN: LAKE CHELAN  
KUTIL PLACE - 085  
MANSON, WA 98831  
COUNTY OF: CHELAN  
STATE: WA  
APPLICATION BY: KELLY FAHEY  
SHEET NO. 5 OF 7 DATE: 7/16/14

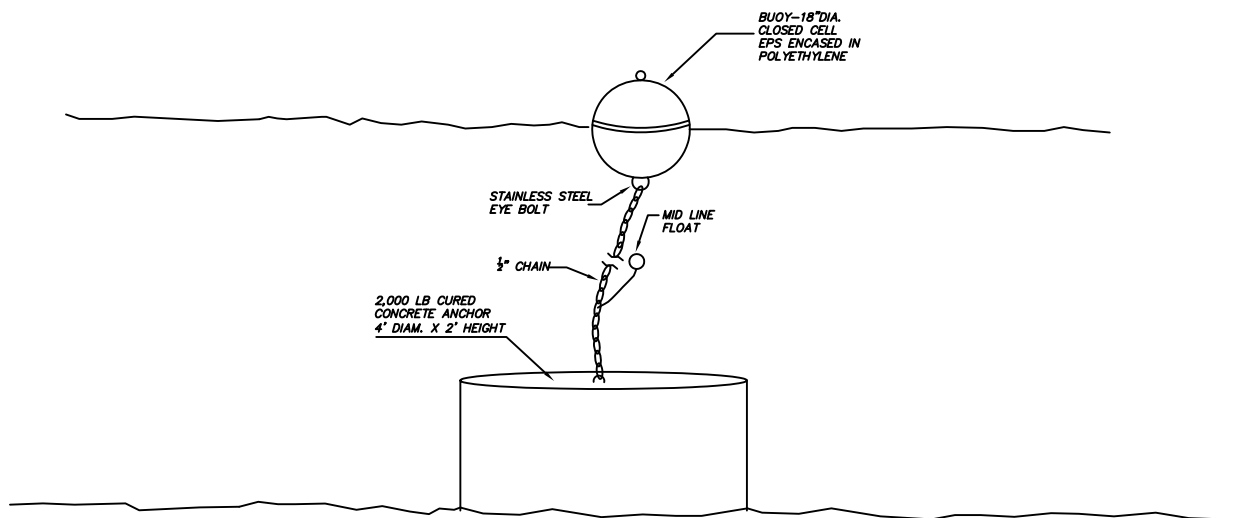
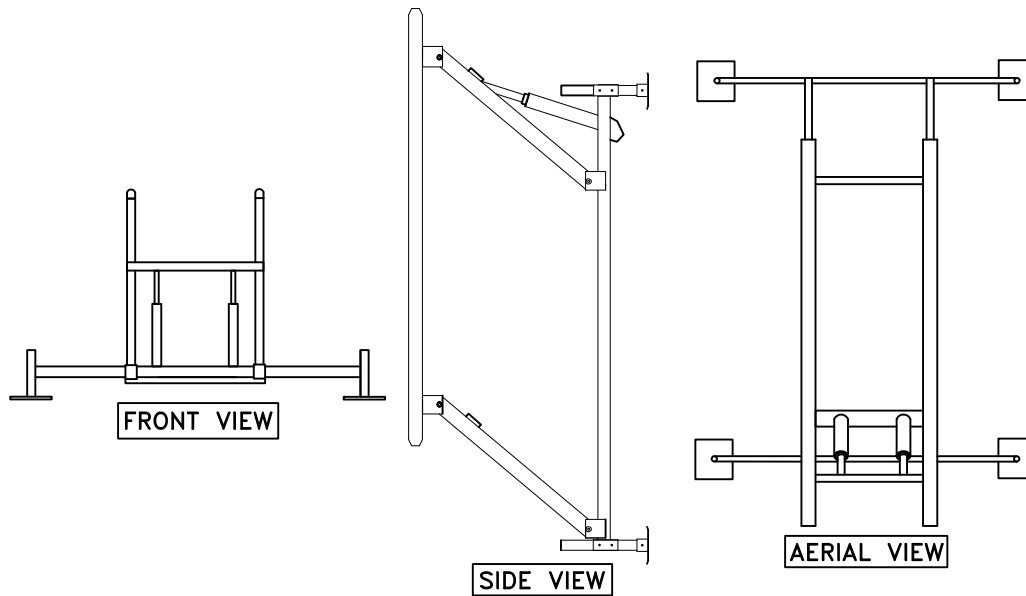
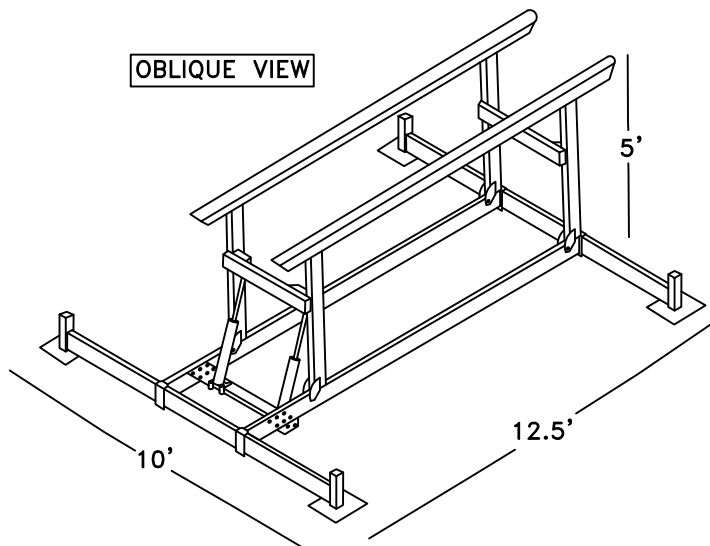

PURPOSE: CONSTRUCTION OF A SINGLE USE PIER,  
STAIRS, BOATLIFT & BUOY

ADJACENT PROPERTY OWNERS:

① THOMAS UTIGARD  
40 JENNINGS STREET  
WENATCHEE, WA 98801

② KELLY FAHEY  
17901 - 41ST PLACE W  
LYNNWOOD, WA 98037

BOATLIFT/BUOY DETAILS



IN: LAKE CHELAN  
KUTIL PLACE - 085  
MANSON, WA 98831

COUNTY OF: CHELAN  
STATE: WA  
APPLICATION BY: KELLY FAHEY

SHEET NO. 6 OF 7 DATE: 7/16/14





PHOTOGRAPH OF ACTUAL LWD IN LAKE CHELAN

LWD COVER STRUCTURE

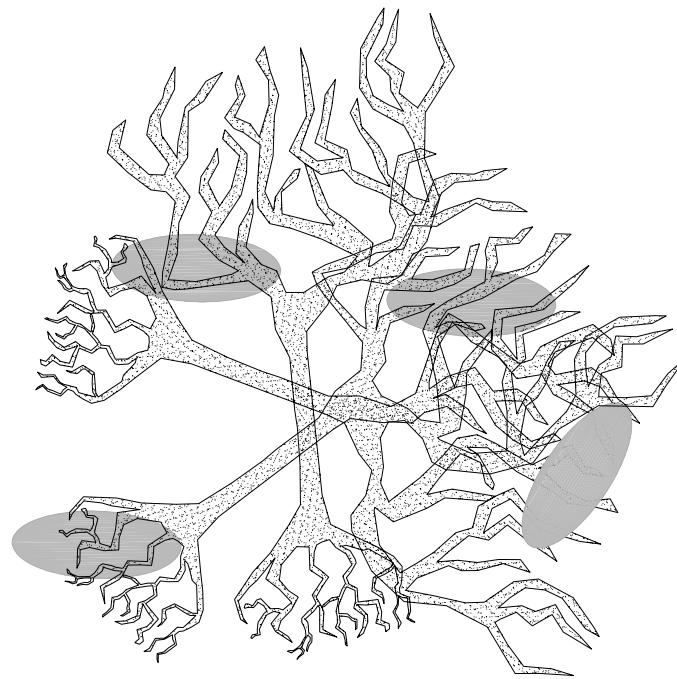

ONE GROUP OF 3 WHOLE  
MATURE FRUIT TREES WITH  
LIMBS AND ROOTWADS  
ATTACHED

ONE GROUP OF 4 WHOLE  
MATURE FRUIT TREES WITH  
LIMBS AND ROOTWADS  
ATTACHED

TREES CABLED TOGETHER  
AND ANCHORED WITH LARGE  
ROCK OR SCREW ANCHORS.  
SEVEN TREES TOTAL.

PURPOSE: CONSTRUCTION OF A SINGLE USE PIER  
STAIRS, BOATLIFT & BUOY

ADJACENT PROPERTY OWNERS:

① THOMAS UTIGARD  
40 JENNINGS STREET  
WENATCHEE, WA 98801

② KELLY FAHEY  
17901 - 41ST PLACE W  
LYNNWOOD, WA 98037

MITIGATION



IN: LAKE CHELAN  
KUTIL PLACE - 085  
MANSON, WA 98831

COUNTY OF: CHELAN  
STATE: WA  
APPLICATION BY: KELLY FAHEY

SHEET NO. 7 OF 7 DATE: 7/16/14