



US Army Corps
of Engineers
Seattle District



Joint Public Notice

Application for a Department of the Army Permit and a Washington Department of Ecology Water Quality Certification and/or Coastal Zone Management Consistency Concurrence

US Army Corps of Engineers

Regulatory Branch
Post Office Box 3755
Seattle, WA 98124-3755
Telephone: (206) 764-6883
ATTN: Darren Habel,
Project Manager

WA Department of Ecology

SEA Program
Post Office Box 47600
Olympia, WA 98504-7600
Telephone: (360) 407-6068
ATTN: SEA Program,
Federal Permit Coordinator

Public Notice Date: February 18, 2015

Expiration Date: March 20, 2015

Reference No.: NWS-2014-966

Name: Snug Harbor Associates

Interested parties are hereby notified that the U.S. Army Corps of Engineers (Corps) and the Washington Department of Ecology (Ecology) have received an application to perform work in waters of the United States as described below and shown on the enclosed drawings dated July 18, 2014.

The Corps will review the work in accordance with Section 10 of the Rivers and Harbors Act. Ecology will review the work pursuant to applicable provisions of the Coastal Zone Management Act.

APPLICANT: Snug Harbor Associates, LLC
Attention: Erik Nelson, Managing Member
723 Hanna Park
Edmonds, Washington 98020-2619
Telephone: (206) 498-5608

AGENT: The Law Offices of Stephanie Johnson O'Day
Attention: Ms. Francine Shaw
P.O. Box 2112
Friday Harbor, Washington 98250
Telephone: (360) 378-6278

LOCATION: In Mitchell Bay, Puget Sound, near Friday Harbor, San Juan Island, San Juan County, Washington.

WORK: To perform work waterward of mean high water to maintain and expand the existing marina structure. The expanded overwater structure will extend an additional 40 feet waterward than the existing and will consist of a new 5-foot by 80-foot grated gangway ramp, grated 8-foot wide mainwalk float and t-floats, grated 6-foot wide mainwalk floats, 5-foot and 4-foot wide solid decked finger floats and thirteen 2-foot by 15-foot kayak finger floats. Replacing the existing 37 creosote piles will be twenty three 10-inch diameter steel piles and ten 12-inch-diameter steel piles. The piles will be installed via a vibratory pile driver. The expanded overwater structure will accommodate up to 66 boats ranging between 22 feet and 48 feet in length. The existing marina structure encompasses a 9,938-square-foot solid decked area. The new structure will encompass a 12,455-square-foot area that will have approximately 2,789 square feet of 60% open area grating.

NWS-2014-966, Snug Harbor Associates (Marina Expansion)

PURPOSE: To provide continued marine access and moorage. Constructed over 40 years ago, the existing structure is in need of replacement, the existing piles are creosote treated, the wooden floats have deteriorated and portions of the structure ground out at low tides.

MITIGATION: The applicant has not submitted a compensatory mitigation plan; however, to minimize the impacts the applicant has proposed to remove 37 existing creosote piles and to replace with only 33 steel piles. In addition, the new gangway, mainwalk and t-floats will be grated to allow light penetration to reduce shading impacts.

ENDANGERED SPECIES: The Endangered Species Act (ESA) requires federal agencies to consult with the National Marine Fisheries Service (NMFS) and/or U.S. Fish and Wildlife Service pursuant to Section 7 of the ESA on all actions that may affect a species listed (or proposed for listing) under the ESA as threatened or endangered or any designated critical habitat. After receipt of comments from this public notice, the Corps will evaluate the potential impacts to proposed and/or listed species and their designated critical habitat.

ESSENTIAL FISH HABITAT: The Magnuson-Stevens Fishery Conservation and Management Act, as amended by the Sustainable Fisheries Act of 1996, requires all Federal agencies to consult with the NMFS on all actions, or proposed actions, permitted, funded, or undertaken by the agency, that may adversely affect Essential Fish Habitat (EFH). The proposed action would impact EFH in the project area. If the Corps determines that the proposed action may adversely affect EFH for federally managed fisheries in Washington waters, the Corps will initiate EFH consultation with the NMFS. The Corps' final determination relative to project impacts and the need for mitigation measures is subject to review by and coordination with the NMFS.

CULTURAL RESOURCES: The Corps has reviewed the latest published version of the National Register of Historic Places, lists of properties determined eligible and other sources of information. Historic properties are recorded near the proposed project. However, they do not occur in the permit area. The proposed work is of such a limited nature and extent waterward of Mean Higher High Water that little likelihood exists for the project to impinge upon an unrecorded historic property. The Corps invites responses to this public notice from Native American Tribes or tribal governments; Federal, State, and local agencies; historical and archeological societies; and other parties likely to have knowledge of or concerns regarding historic properties and sites of religious and cultural significance at or near the project area. After receipt of comments from this public notice, the Corps will evaluate potential impacts and consult with the State Historic Preservation Officer and Native American Tribes in accordance with Section 106 of the National Historic Preservation Act, as appropriate.

PUBLIC HEARING: Any person may request, in writing, within the comment period specified in this notice, that a public hearing be held to consider this application. Requests for public hearings shall state, with particularity, the reasons for holding a public hearing.

EVALUATION – CORPS: The decision whether to issue a permit will be based on an evaluation of the probable impacts, including cumulative impacts, of the proposed activity on the public interest. That decision will reflect the national concern for both protection and utilization of important resources. The benefits, which reasonably may be expected to accrue from the proposal, must be balanced against its reasonably foreseeable detriments. All factors which may be relevant to the proposal will be considered, including the cumulative effects thereof; among those are conservation, economics, aesthetics, general environmental concerns, wetlands, historic properties, fish and wildlife values, flood hazards, floodplain values, land use, navigation, shoreline erosion and accretion, recreation, water supply and conservation, water quality, energy needs, safety, food and fiber production, mineral needs, considerations of property ownership, and, in general, the needs and welfare of the people.

The Corps is soliciting comments from the public; Native American Nations or tribal governments; Federal, State, and local agencies and officials; and other interested parties in order to consider and evaluate the impacts of this

NWS-2014-966, Snug Harbor Associates (Marina Expansion)

activity. Any comments received will be considered by the Corps to determine whether to issue, modify, condition or deny a permit for the work. To make this decision, comments are used to assess impacts on endangered species, historic properties, water quality, general environmental effects, and the other public interest factors listed above. Comments are used in the preparation of an Environmental Assessment and/or an Environmental Impact Statement pursuant to the National Environmental Policy Act. Comments are also used to determine the need for a public hearing and to determine the overall public interest of the activity.

EVALUATION – ECOLOGY: Ecology is soliciting comments from the public; Federal, Native American Nations or tribal governments, State, and local agencies and officials; and other interested parties in order to consider and evaluate the impacts of this activity. Ecology will be considering all comments to determine whether to certify or deny certification for the proposed project.

ADDITIONAL EVALUATION: This proposal is the subject of Shorelines Substantial Development Permit No. PSJ000-14-0016, being processed by the San Juan County Department of Community Development.

COMMENT AND REVIEW PERIOD: Conventional mail or e-mail comments on this public notice will be accepted and made part of the record and will be considered in determining whether it would be in the public interest to authorize this proposal. In order to be accepted, e-mail comments must originate from the author's e-mail account and must include on the subject line of the e-mail message the permit applicant's name and reference number as shown below. Either conventional mail or e-mail comments must include the permit applicant's name and reference number, as shown below, and the commentator's name, address, and phone number. All comments whether conventional mail or e-mail must reach this office, no later than the expiration date of this public notice to ensure consideration.

CORPS COMMENTS: All e-mail comments should be sent to darren.habel@usace.army.mil. Conventional mail comments should be sent to: U.S. Army Corps of Engineers, Regulatory Branch, Attention: Darren Habel, P.O. Box 3755, Seattle, Washington 98124-3755. All comments received will become part of the administrative record and are subject to public release under the Freedom of Information Act including any personally identifiable information such as names, phone numbers, and addresses.

ECOLOGY COMMENTS: Any person desiring to present views on the project pertaining to a request for water quality certification under Section 401 of the CWA and/or Coastal Zone Management consistency concurrence, may do so by submitting written comments to the following address: Washington State Department of Ecology, Attention: Federal Permit Coordinator, P.O. Box 47600, Olympia, Washington 98504-7600, or e-mail to ecyrefedpermits@ecy.wa.gov.

To ensure proper consideration of all comments, responders must include the following name and reference number in the text of their comments: Snug Harbor Associates, NWS-2014-966.

Encl: Figures (10)

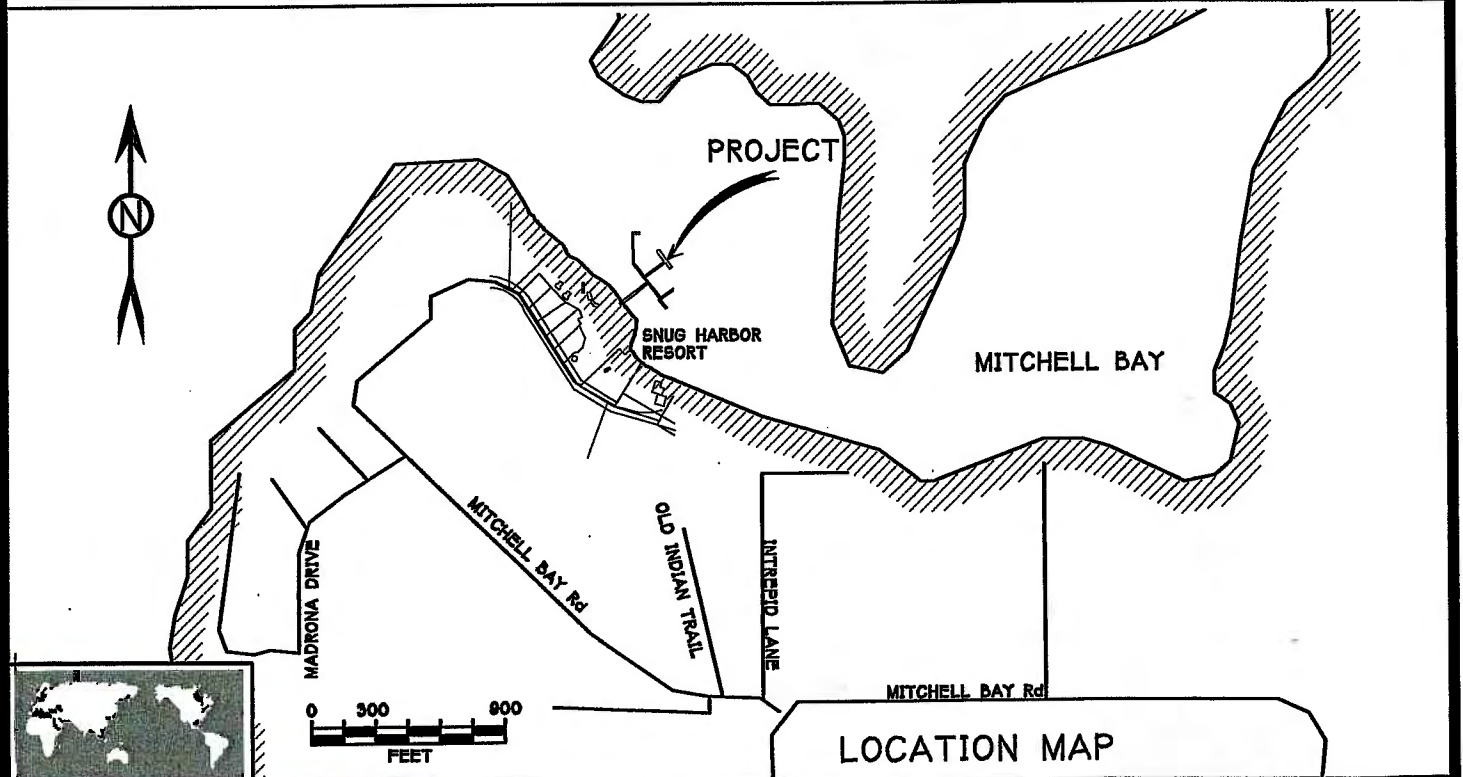
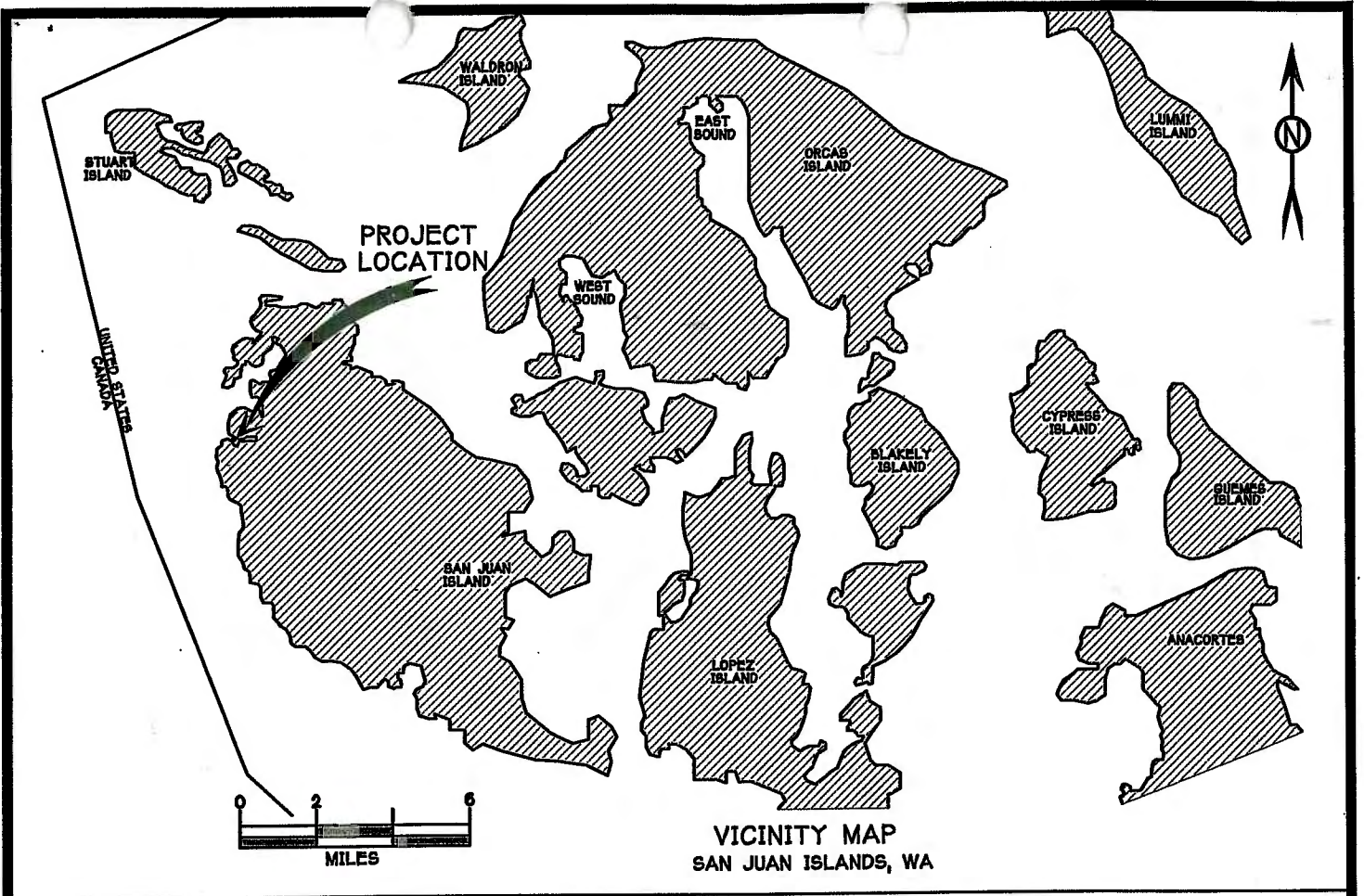

TRANSPAC
MARINAS
P.O. BOX 1169
ANACORTES
WASHINGTON
U.S.A. 98221
(360) 293-8888

AJD
(360) 770-1746

PURPOSE: PROPOSED MARINA REPLACEMENT
APPLICANT:
SNUG HARBOR ASSOCIATES LLC
1997 MITCHELL BAY Rd
SAN JUAN ISLAND, WA 98260
c/o ERIC NELSON
723 HANNA PARK
EDMONDS, WA 98020-2619
IN MITCHELL BAY
AT: SAN JUAN ISLAND
STATE: WASHINGTON
DATUM: MLLW = CD
LATITUDE: 48.5706804 deg
LONGITUDE: -123.1882217 deg

APPLICATION REFERENCE No:
NWS-2014-966
**SNUG HARBOR MARINA
VICINITY MAP**

THIS DRAWING IS THE PROPERTY OF AND CONTAINS INFORMATION WHICH BELONGS TO TRANSPAC MARINAS, INC. IT IS BEING LOANED WITH THE UNDERSTANDING THAT IT MAY NOT BE REPRODUCED OR USED IN ANY WAY THAT WOULD BE INJURIOUS TO TRANSPAC'S INTERESTS. DETAILS MAY BE PROTECTED UNDER ONE OR MORE OF THE FOLLOWING U.S. PATENTS: 4,709,647 - 4,887,854 - 4,940,021 - 5,347,948 - 5,329,012 - 6,450,737

DATE: 18 JULY 14	JOB NO. 1417	SHEET: OF 1 OF 10	REVISED:
---------------------	-----------------	----------------------	----------

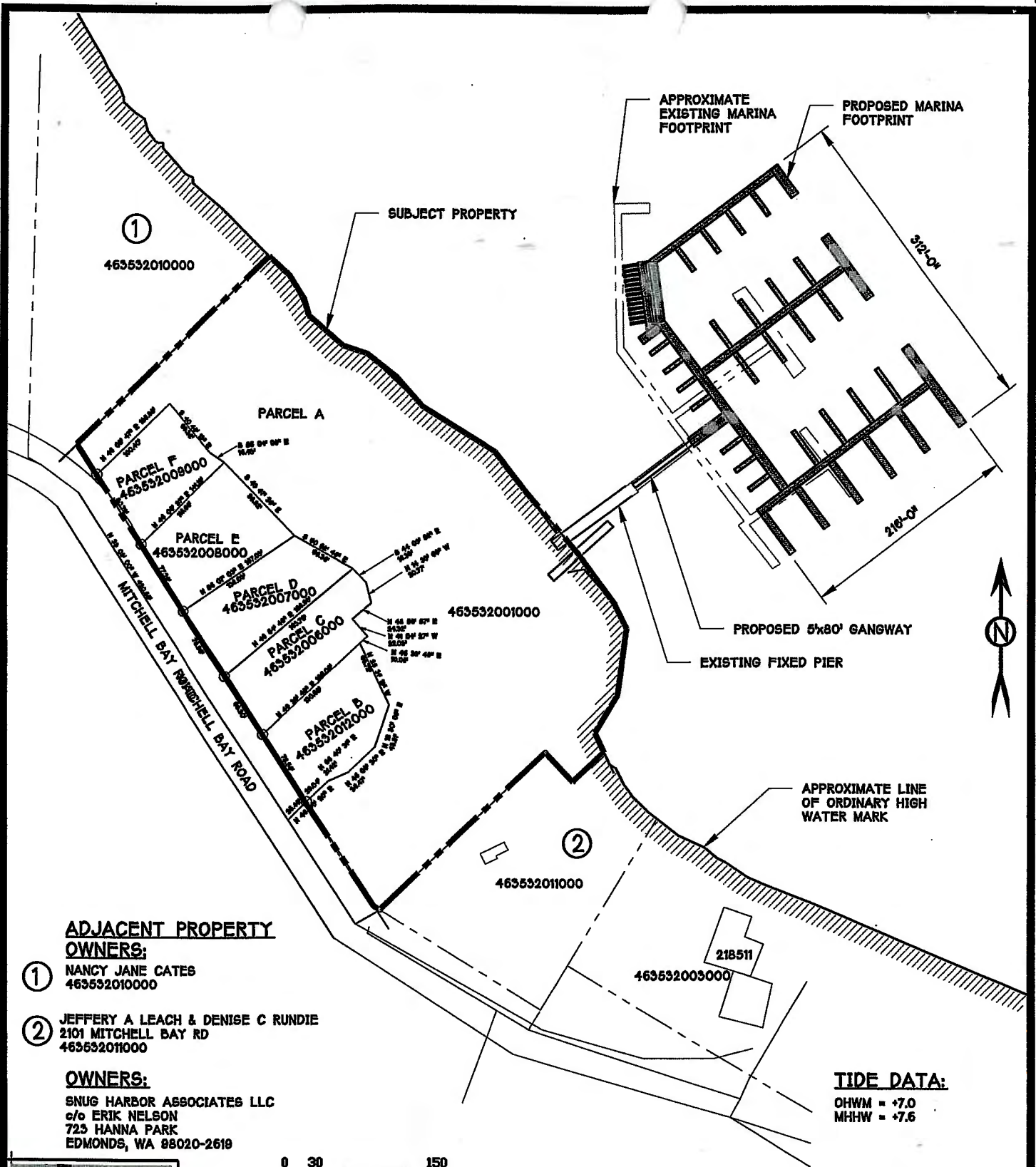

ADJACENT PROPERTY OWNERS:

- ① NANCY JANE CATES
463532010000
- ② JEFFERY A LEACH & DENISE C RUNDIE
2101 MITCHELL BAY RD
463532011000

OWNERS:

SNUG HARBOR ASSOCIATES LLC
c/o ERIK NELSON
723 HANNA PARK
EDMONDS, WA 98020-2619

TIDE DATA:

OHWM = +7.0
MHHW = +7.6



TRANSPAC MARINAS
P.O. BOX 1169
ANACORTES WASHINGTON U.S.A. 98221
(360) 293-8888

AJD
(360) 770-1746

PURPOSE: PROPOSED MARINA REPLACEMENT

APPLICANT:
SNUG HARBOR ASSOCIATES LLC
1897 MITCHELL BAY Rd
SAN JUAN ISLAND, WA 98250
c/o ERIK NELSON
723 HANNA PARK
EDMONDS, WA 98020-2619

IN: MITCHELL BAY
AT: SAN JUAN ISLAND
STATE: WASHINGTON
DATUM: MLLW = 0.0'
LATITUDE: 48.5708908 deg
LONGITUDE: -123.1682117 deg

APPLICATION REFERENCE No:
NWS-2014-966

SNUG HARBOR MARINA PARCEL MAP

THIS DRAWING IS THE PROPERTY OF AND CONTAINS INFORMATION WHICH BELONGS TO TRANSPAC MARINAS, INC. IT IS BEING LOANED WITH THE UNDERSTANDING THAT IT MAY NOT BE REPRODUCED OR USED IN ANY WAY THAT WOULD BE INJURIOUS TO TRANSPAC'S INTERESTS. DETAILS MAY BE PROTECTED UNDER ONE OR MORE OF THE FOLLOWING U.S. PATENTS: 4,709,847 - 4,887,854 - 4,940,021 - 5,347,948 - 5,529,012 - 6,450,737

DATE: 18 JULY 14	JOB NO. 1417	SHEET: OF 2 OF 10	REVISED:
----------------------------	------------------------	-----------------------------	-----------------

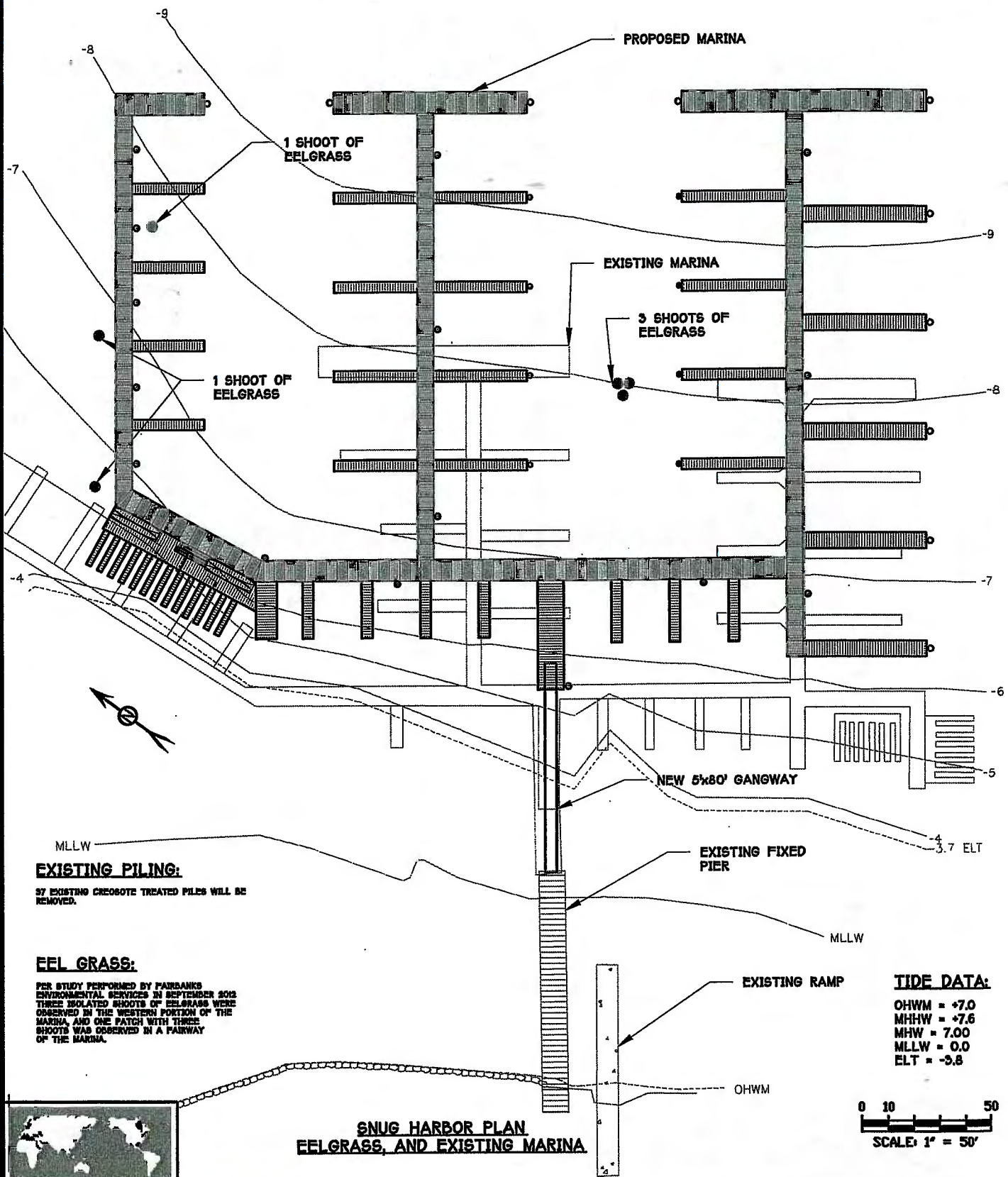

EXISTING PILING:

37 EXISTING CREOSOTE TREATED PILES WILL BE REMOVED.

EEL GRASS:

PER STUDY PERFORMED BY FAIRBANKS ENVIRONMENTAL SERVICES IN SEPTEMBER 2012 THREE ISOLATED SHOOTS OF EELGRASS WERE OBSERVED IN THE WESTERN PORTION OF THE MARINA, AND ONE PATCH WITH THREE SHOOTS WAS OBSERVED IN A FAIRWAY OF THE MARINA.

TIDE DATA:

OHWM = +7.0
 MHHW = +7.6
 MHW = 7.00
 MLLW = 0.0
 ELT = -5.8

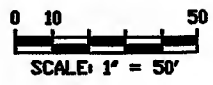

**SNUG HARBOR PLAN
 EELGRASS, AND EXISTING MARINA**



**TRANSPAC
 MARINAS**
 P.O. BOX 1169
 ANACORTES
 WASHINGTON
 U.S.A. 98221
 (360) 293-8888

AJD
 (360) 770-1746

PURPOSE: PROPOSED MARINA REPLACEMENT

APPLICANT:
 SNUG HARBOR ASSOCIATES LLC
 1987 MITCHELL BAY Rd
 SAN JUAN ISLAND, WA 98250
 c/o ERIK NELSON
 723 HANNA PARK
 EDMONDS, WA 98020-2619

**IN: MITCHELL BAY
 AT: SAN JUAN ISLAND
 STATE: WASHINGTON
 DATUM: MLLW = 0.0'
 LATITUDE: 48.5706806 deg
 LONGITUDE: -123.1682217 deg**

APPLICATION REFERENCE No:

NWS-2014-966

**SNUG HARBOR MARINA
 MARINA PLAN
 EELGRASS & EXIST MARINA**

DATE: 18 JULY 14	JOB NO.: 1417	SHEET: OF 3 OF 10	REVISED:
----------------------------	-------------------------	-----------------------------	-----------------

THIS DRAWING IS THE PROPERTY OF AND CONTAINS INFORMATION WHICH BELONGS TO TRANSPAC MARINAS, INC. IT IS BEING LOANED WITH THE UNDERSTANDING THAT IT MAY NOT BE REPRODUCED OR USED IN ANY WAY THAT WOULD BE INJURIOUS TO TRANSPAC'S INTERESTS. DETAILS MAY BE PROTECTED UNDER ONE OR MORE OF THE FOLLOWING U.S. PATENTS: 4,709,647 - 4,887,854 - 4,940,021 - 5,347,948 - 5,529,012 - 6,450,737

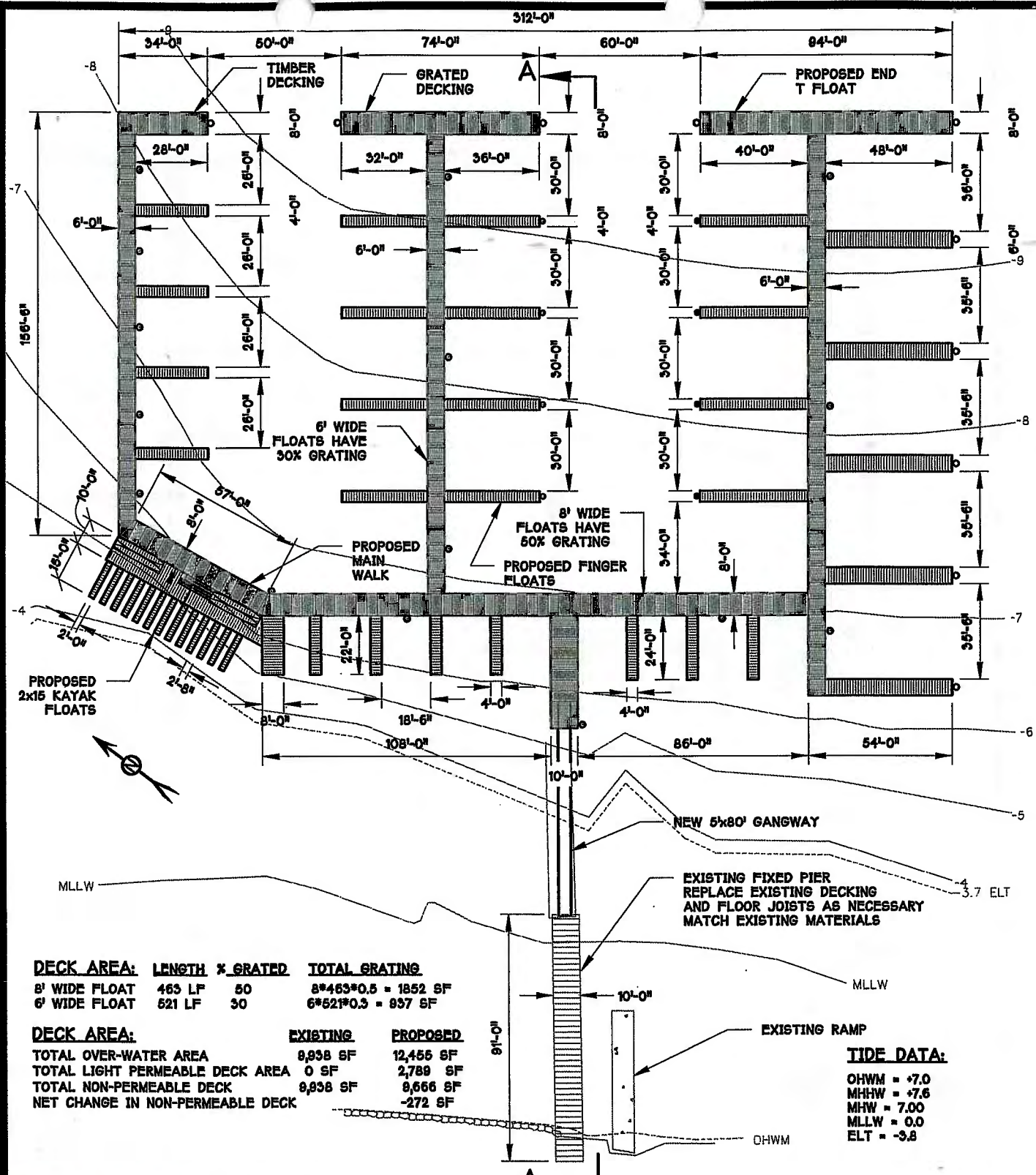

DECK AREA:	LENGTH	% GRATED	TOTAL GRATING
8' WIDE FLOAT	463 LF	50	8*463*0.5 = 1852 SF
6' WIDE FLOAT	521 LF	30	6*521*0.5 = 957 SF

DECK AREA:	EXISTING	PROPOSED
TOTAL OVER-WATER AREA	8,938 SF	12,455 SF
TOTAL LIGHT PERMEABLE DECK AREA	0 SF	2,789 SF
TOTAL NON-PERMEABLE DECK	8,938 SF	9,666 SF
NET CHANGE IN NON-PERMEABLE DECK		-272 SF

TIDE DATA:

OHWM = +7.0
 MHHW = +7.6
 MHW = 7.00
 MLLW = 0.0
 ELT = -3.8

PILES, PROPOSED:

- 10 3/4"x0.375 WALL PILE, 23 EA
 - 12 3/4"x0.375 WALL PILE, 10 EA
- PILE ARE A252, GR 3, HOT DIP GALVANIZED
 MIN 20' PENETRATION, CUTOFF = +17 MLLW

**SHT 5
 SNUG HARBOR PLAN**



**TRANSPAC
 MARINAS**

P.O. BOX 1169
 ANACORTES
 WASHINGTON
 U.S.A. 98221
 (360) 293-8888

AJD
 (360) 770-1746

PURPOSE: PROPOSED MARINA REPLACEMENT

APPLICANT:
 SNUG HARBOR ASSOCIATES LLC
 1887 MITCHELL BAY Rd
 SAN JUAN ISLAND, WA 98280
 c/o ERIC NELSON
 723 HANNA PARK
 EDMONDS, WA 98020-2619

IN: MITCHELL BAY
 AT: SAN JUAN ISLAND
 STATE: WASHINGTON
 DATUM: MLLW = 0.0'
 LATITUDE: 48.5708806 deg
 LONGITUDE: -123.1682217 deg

APPLICATION REFERENCE No:

NWS-2014-966

**SNUG HARBOR MARINA
 MARINA PLAN**

THIS DRAWING IS THE PROPERTY OF AND CONTAINS INFORMATION WHICH BELONGS TO TRANSPAC MARINAS, INC. IT IS BEING LOANED WITH THE UNDERSTANDING THAT IT MAY NOT BE REPRODUCED OR USED IN ANY WAY THAT WOULD BE INJURIOUS TO TRANSPAC'S INTERESTS. DETAILS MAY BE PROTECTED UNDER ONE OR MORE OF THE FOLLOWING U.S. PATENTS: 4,709,647 - 4,887,654 - 4,940,021 - 3,347,948 - 5,529,012 - 6,450,737

DATE: 18 JULY 14	JOB NO. 1417	SHEET: OF 4 OF 10	REVISED:
---------------------	-----------------	----------------------	----------

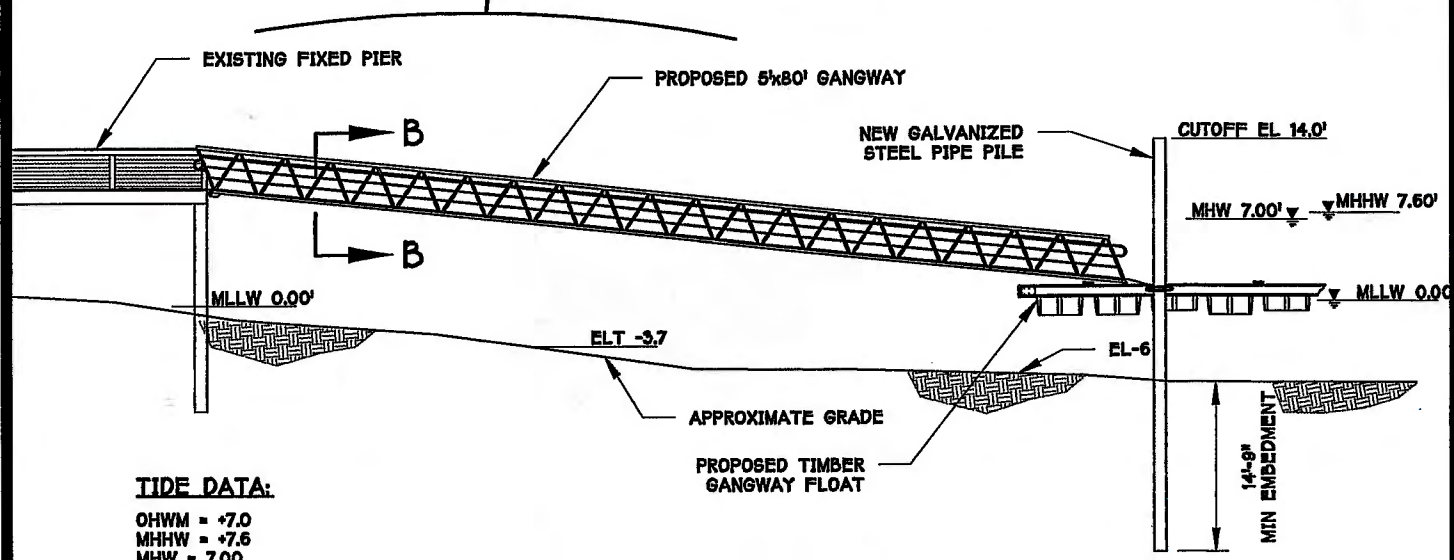
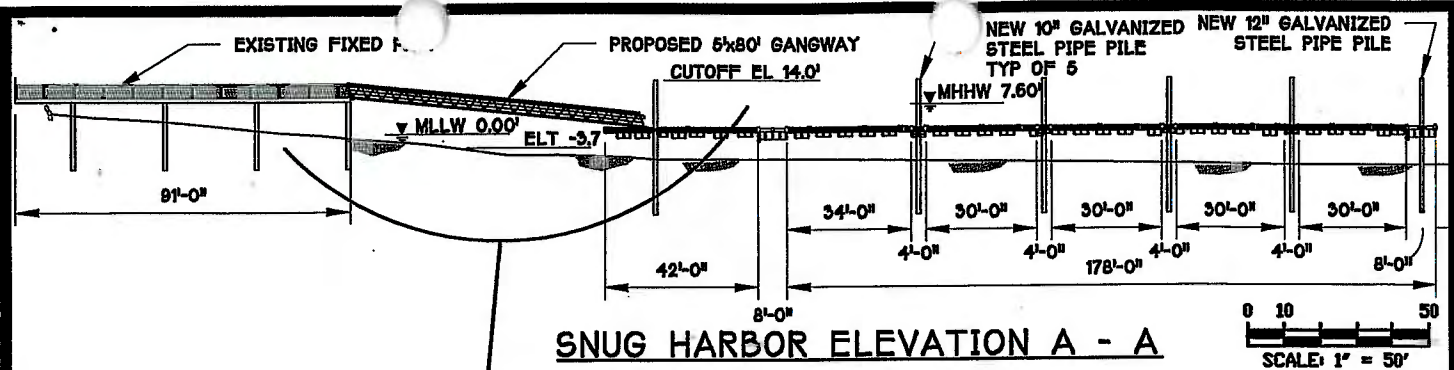

TIDE DATA:
 OHWM = +7.0
 MHHW = +7.6
 MHW = 7.00
 MLLW = 0.0
 ELT = -3.8

REPLACE EXISTING DECKING, RAILING AND JOISTS AS REQUIRED TO ENSURE CONTINUED SERVICE FOR FIXED PIER. MATCH EXISTING.

FOR CONCEPTUAL USE ONLY
 NOT FOR CONSTRUCTION

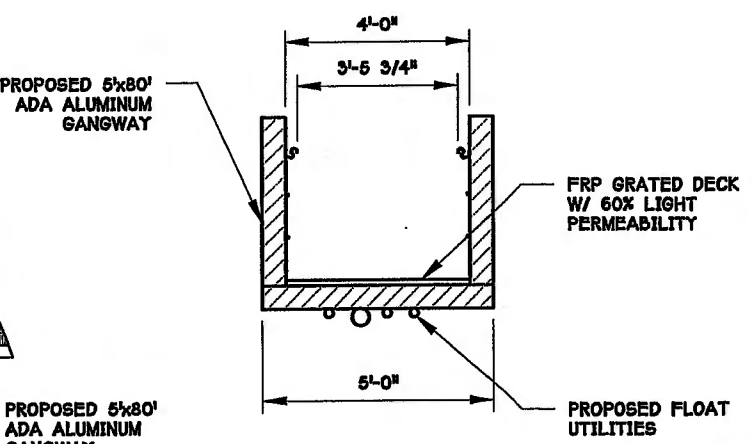
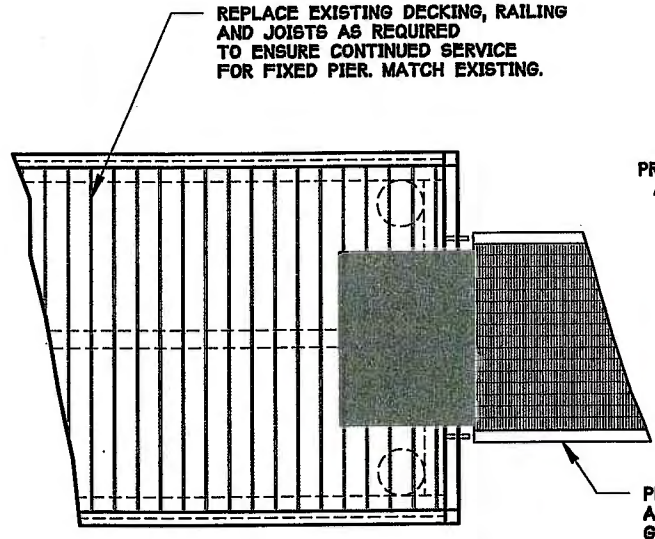

TRANSPAC MARINAS
 P.O. BOX 1169
 ANACORTES WASHINGTON U.S.A. 98221
 (360) 293-8888

AJD
 (360) 770-1746

PURPOSE: PROPOSED MARINA REPLACEMENT
APPLICANT: SNUG HARBOR ASSOCIATES LLC, 1897 MITCHELL BAY Rd, SAN JUAN ISLAND, WA 98250, c/o ERIK NELSON, 723 HANNA PARK, EDMONDS, WA 98020-2618
IN: MITCHELL BAY AT: SAN JUAN ISLAND STATE: WASHINGTON DATUM: MLLW = 0.0' LATITUDE: 48.5708806 deg LONGITUDE: -123.1692217 deg

APPLICATION REFERENCE No: NWS-2014-966
SNUG HARBOR MARINA GANGWAY AND FIXED PIER ELEVATION & SECTIONS

THIS DRAWING IS THE PROPERTY OF AND CONTAINS INFORMATION WHICH BELONGS TO TRANSPAC MARINAS, INC. IT IS BEING LOANED WITH THE UNDERSTANDING THAT IT MAY NOT BE REPRODUCED OR USED IN ANY WAY THAT WOULD BE INJURIOUS TO TRANSPAC'S INTERESTS. DETAILS MAY BE PROTECTED UNDER ONE OR MORE OF THE FOLLOWING U.S. PATENTS: 4,709,647 - 4,887,834 - 4,940,021 - 5,347,948 - 5,529,012 - 6,450,737

DATE: 18 JULY 14	JOB NO. 1417	SHEET: 5 OF 10	REVISED:
-------------------------	---------------------	-----------------------	-----------------

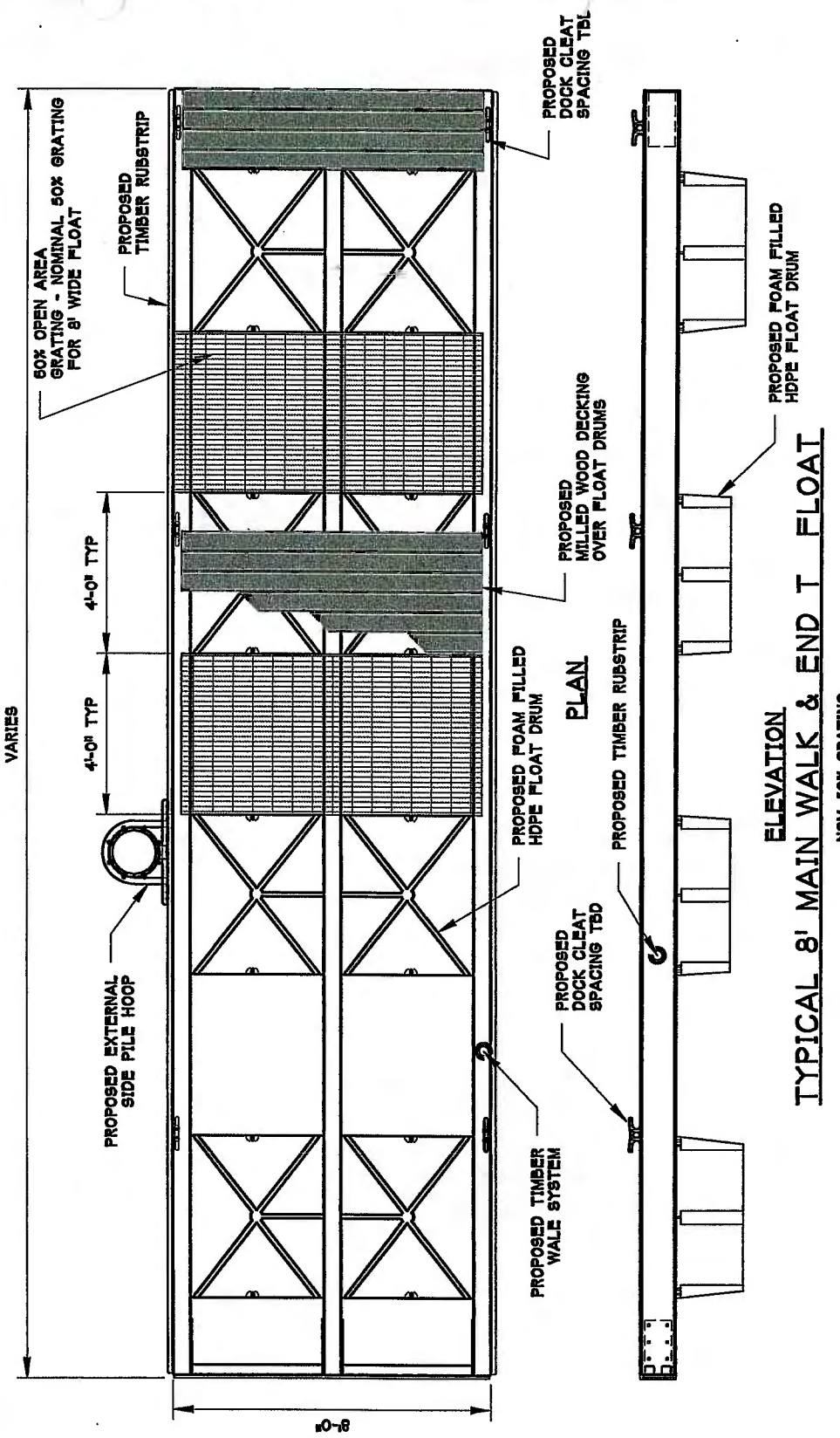

FOR CONCEPTUAL USE ONLY
NOT FOR CONSTRUCTION

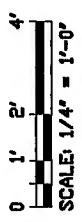

**TRANSPAC
MARINAS**
P.O. BOX 1169
ANACORTES
WASHINGTON
U.S.A. 98221
(360) 293-8888

AJD
(360) 770-1746

PURPOSE: PROPOSED MARINA REPLACEMENT

APPLICANT:
SNUG HARBOR ASSOCIATES LLC
1967 MITCHELL BAY Rd
SAN JUAN ISLAND, WA 98250
c/o ERIC NELSON
723 HARVA PARK
EDMONDS, WA 98020-2619

**IN: MITCHELL BAY
AT: SAN JUAN ISLAND
STATE: WASHINGTON
DATUM: MLLW = 0.0'
LATITUDE: 48.5706806 deg
LONGITUDE: -125.1682317 deg**

APPLICATION REFERENCE No:
NWS-2014-966

**SNUG HARBOR MARINA
TYPICAL 8' MAIN WALK FLOAT**

THIS DRAWING IS THE PROPERTY OF AND CONTAINS INFORMATION WHICH BELONGS TO TRANSPAC MARINAS, INC. IT IS BEING LOANED WITH THE UNDERSTANDING THAT IT MAY NOT BE REPRODUCED OR USED IN ANY WAY THAT WOULD BE INJURIOUS TO TRANSPAC'S INTERESTS. DETAILS MAY BE PROTECTED UNDER ONE OR MORE OF THE FOLLOWING U.S. PATENTS: 4,709,847 - 4,887,854 - 4,940,021 - 5,347,948 - 5,529,012 - 6,450,737

DATE: 18 JULY 14	JOB NO. 1417	SHEET: OF 6 OF 10	REVISED:
----------------------------	------------------------	-----------------------------	-----------------

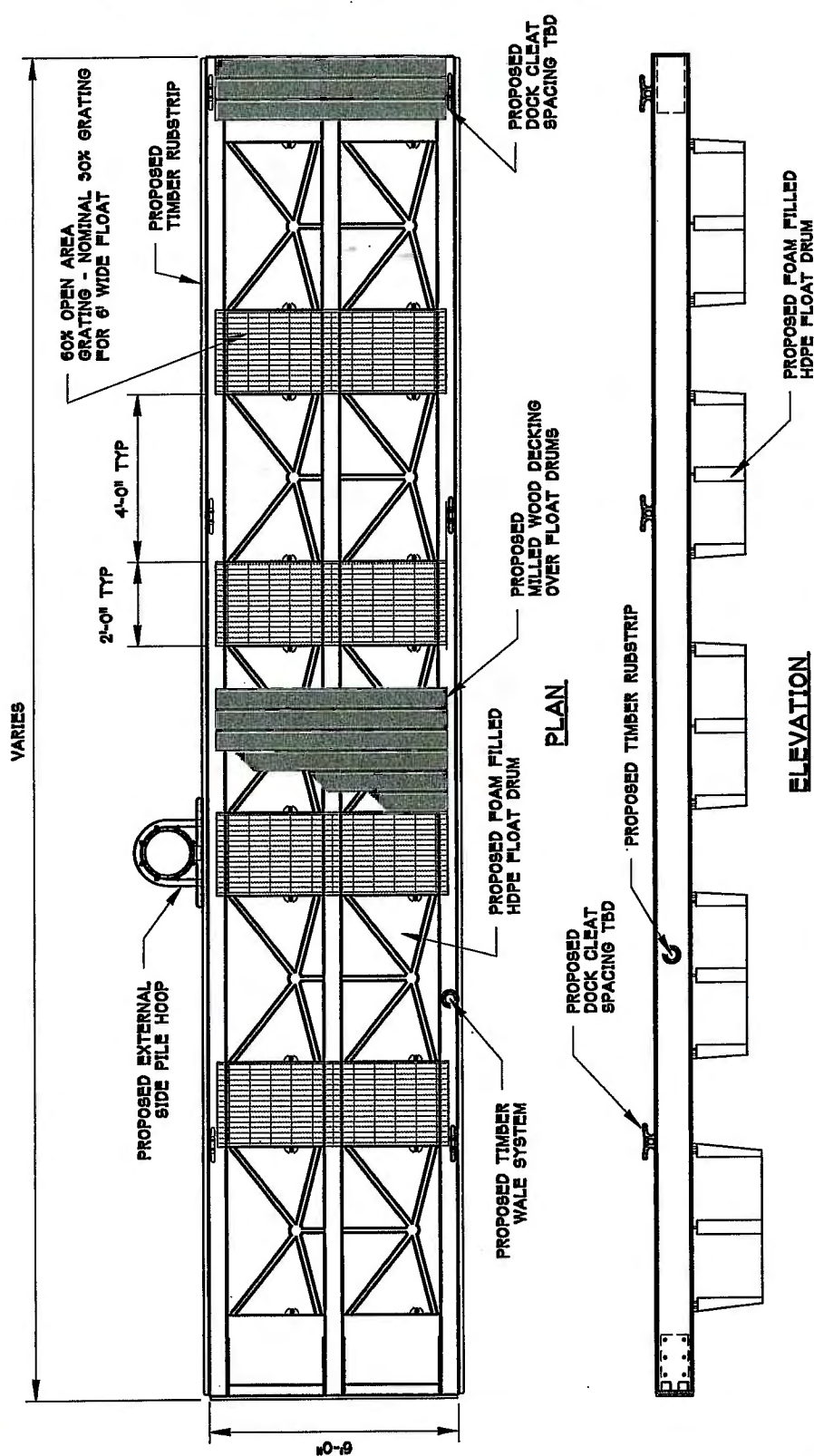

TYPICAL 6' MAIN WALK
NOM 30X GRATING

FOR CONCEPTUAL USE ONLY
NOT FOR CONSTRUCTION

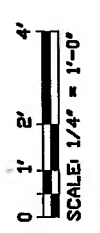

**TRANSPAC
MARINAS**
P.O. BOX 1169
ANACORTES
WASHINGTON
U.S.A. 98221
(360) 293-8888

AJD
(360) 770-1746

PURPOSE: PROPOSED MARINA REPLACEMENT

APPLICANT:
SNUG HARBOR ASSOCIATES LLC
1907 MITCHELL BAY RD
SAN JUAN ISLAND, WA 98250
c/o ERIC NELSON
723 HANNA PARK
EDMONDS, WA 98020-2619

IN: MITCHELL BAY
AT: SAN JUAN ISLAND
STATE: WASHINGTON
DATUM: MLLW ± 0.0'
LATITUDE: 48.3708806 deg
LONGITUDE: -123.1652217 deg

APPLICATION REFERENCE No:
NWS-2014-966

**SNUG HARBOR MARINA
TYPICAL 6' MAIN WALK FLOAT**

THIS DRAWING IS THE PROPERTY OF AND CONTAINS INFORMATION WHICH BELONGS TO TRANSPAC MARINAS, INC. IT IS BEING LOANED WITH THE UNDERSTANDING THAT IT MAY NOT BE REPRODUCED OR USED IN ANY WAY THAT WOULD BE INJURIOUS TO TRANSPAC'S INTERESTS. DETAILS MAY BE PROTECTED UNDER ONE OR MORE OF THE FOLLOWING U.S. PATENTS: 4,709,847 - 4,887,854 - 4,940,021 - 5,347,948 - 5,529,012 - 6,450,737

DATE: 18 JULY 14	JOB NO. 1417	SHEET: OF 7 OF 10	REVISED:
---------------------	-----------------	----------------------	----------

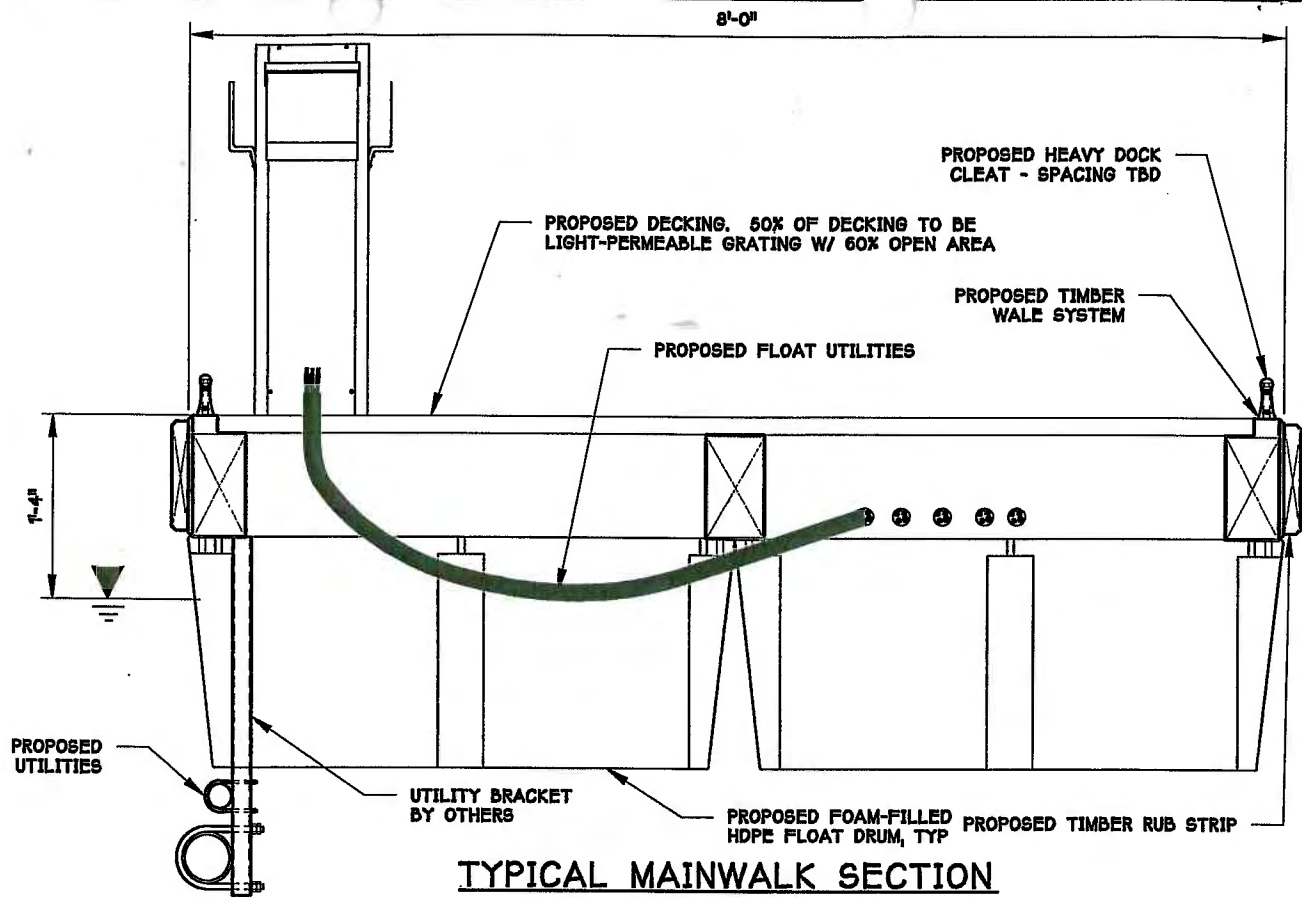

TYPICAL MAINWALK SECTION

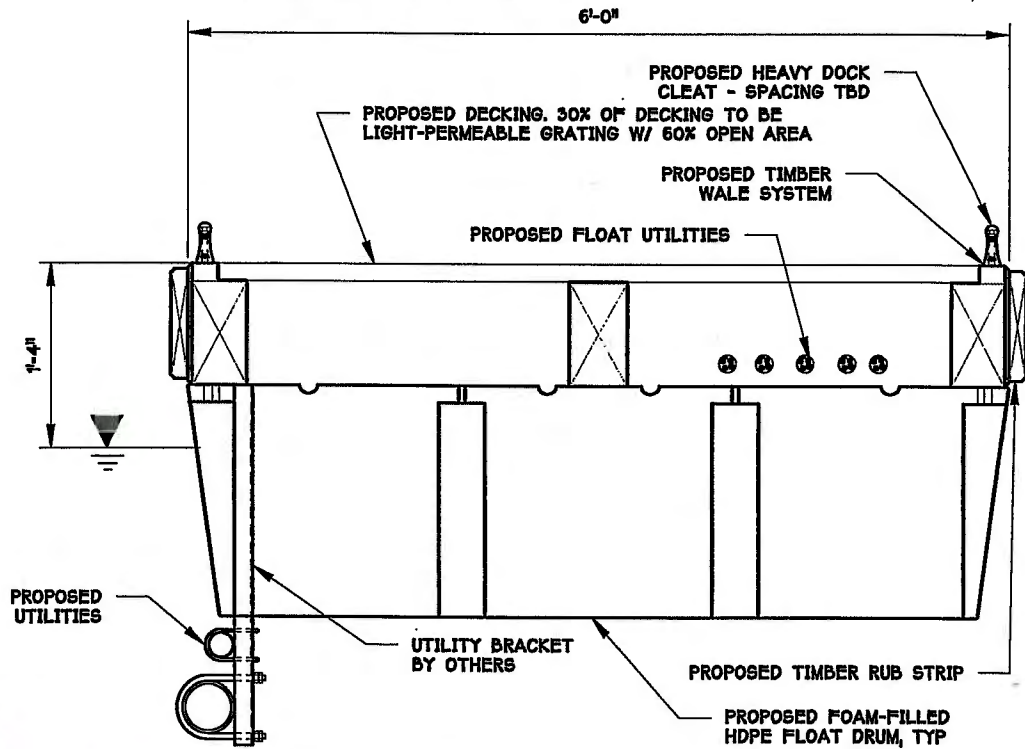

TYPICAL TRANSIENT WALK SECTION



TRANSPAC
MARINAS

P.O. BOX 1169
ANACORTES
WASHINGTON
U.S.A. 98221
(360) 293-8888

AJD

(360) 770-1746

PURPOSE: PROPOSED MARINA REPLACEMENT

APPLICANT:
SNUG HARBOR ASSOCIATES LLC
1807 MITCHELL BAY Rd
SAN JUAN ISLAND, WA 98260
c/o ERIK NELSON
723 HANNA PARK
EDMONDS, WA 98020-2619

IN: MITCHELL BAY
AT: SAN JUAN ISLAND
STATE: WASHINGTON
DATE: MLLW = 0.0'
LATITUDE: 48.5708806 deg
LONGITUDE: -123.1682217 deg

APPLICATION REFERENCE No:
NWS-2014-966

**SNUG HARBOR MARINA
MAINWALK & TRANSIENT
FLOAT SECTIONS**

THIS DRAWING IS THE PROPERTY OF AND CONTAINS INFORMATION WHICH BELONGS TO TRANSPAC MARINAS, INC. IT IS BEING LOANED WITH THE UNDERSTANDING THAT IT MAY NOT BE REPRODUCED OR USED IN ANY WAY THAT WOULD BE INJURIOUS TO TRANSPAC'S INTERESTS. DETAILS MAY BE PROTECTED UNDER ONE OR MORE OF THE FOLLOWING U.S. PATENTS: 4,709,847 - 4,887,834 - 4,940,021 - 5,347,948 - 5,529,012 - 6,450,737

DATE: 18 JULY 14	JOB NO. 1417	SHEET: OF 8 OF 10	REVISED:
---------------------	-----------------	----------------------	----------

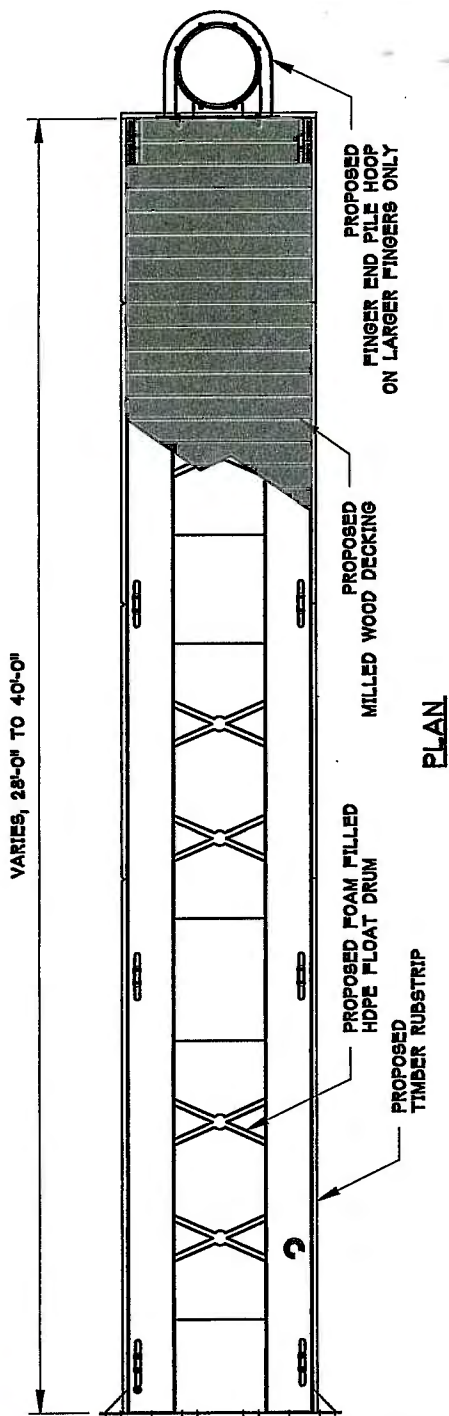

PLAN

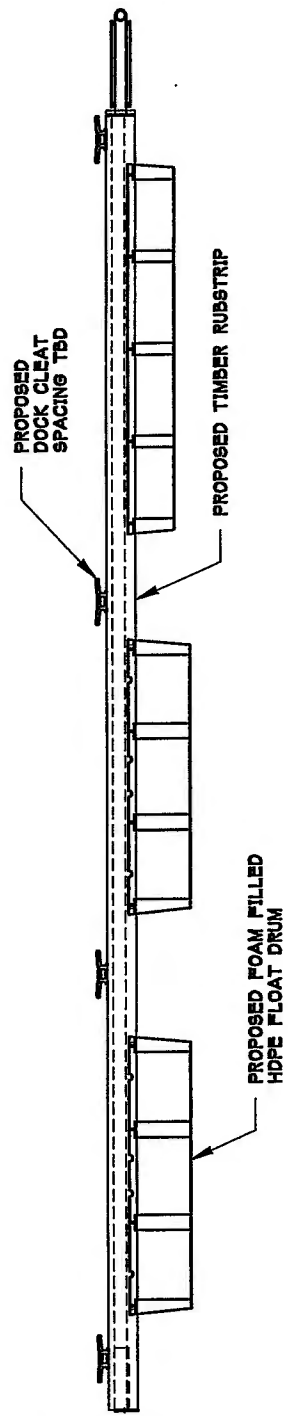

ELEVATION
TYPICAL FINGER FLOAT

FOR CONCEPTUAL USE ONLY
NOT FOR CONSTRUCTION

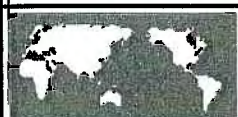
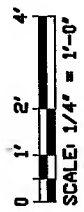

**TRANSPAC
MARINAS**

P.O. BOX 1169
ANACORTES
WASHINGTON
U.S.A. 98221
(360) 293-8888

AJD

(360) 770-1746

PURPOSE: PROPOSED MARINA REPLACEMENT

APPLICANT:
SNUG HARBOR ASSOCIATES LLC
1987 MITCHELL BAY Rd
SAN JUAN ISLAND, WA 98260
c/o ERIC NELSON
723 HANNA PARK
EDMONDS, WA 98020-2619

IN: MITCHELL BAY
AT: SAN JUAN ISLAND
STATE: WASHINGTON
DATUM: MLLW = 0.0'
LATITUDE: 48.5706806 deg
LONGITUDE: -123.1682217 deg

APPLICATION REFERENCE No:
NWS-2014-9166

**SNUG HARBOR MARINA
TYPICAL FINGER FLOAT**

THIS DRAWING IS THE PROPERTY OF AND CONTAINS INFORMATION WHICH BELONGS TO TRANSPAC MARINAS, INC. IT IS BEING LOANED WITH THE UNDERSTANDING THAT IT MAY NOT BE REPRODUCED OR USED IN ANY WAY THAT WOULD BE INJURIOUS TO TRANSPAC'S INTERESTS. DETAILS MAY BE PROTECTED UNDER ONE OR MORE OF THE FOLLOWING U.S. PATENTS: 4,709,847 - 4,887,854 - 4,940,021 - 5,347,948 - 5,528,012 - 6,450,737

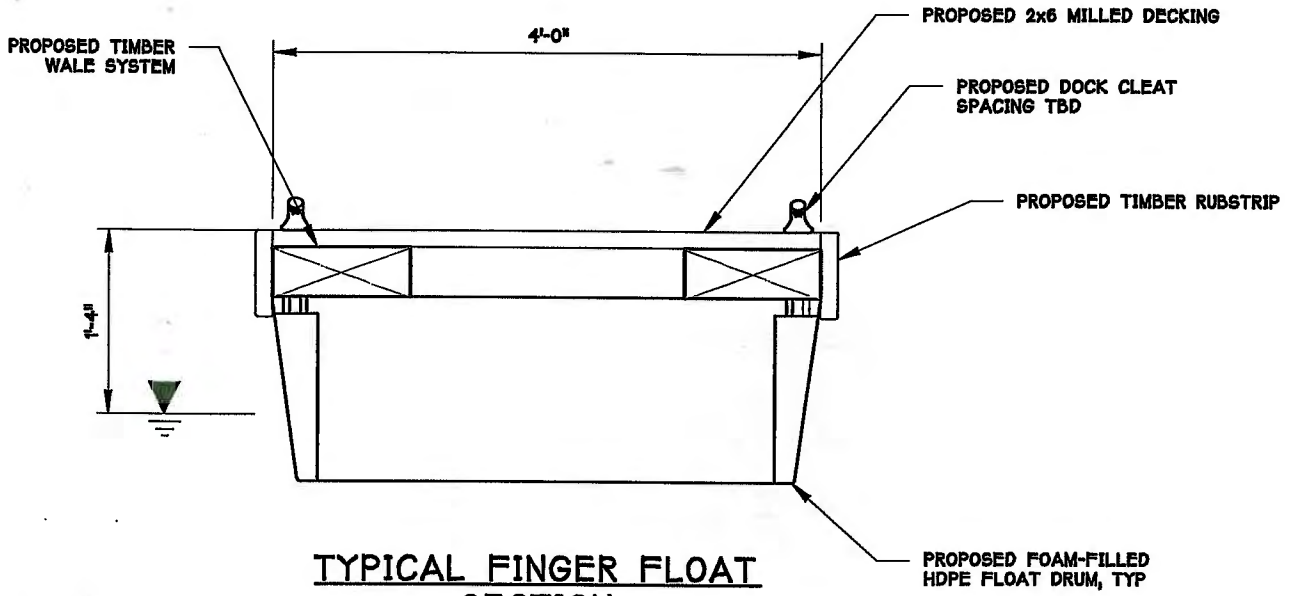

TYPICAL FINGER FLOAT SECTION

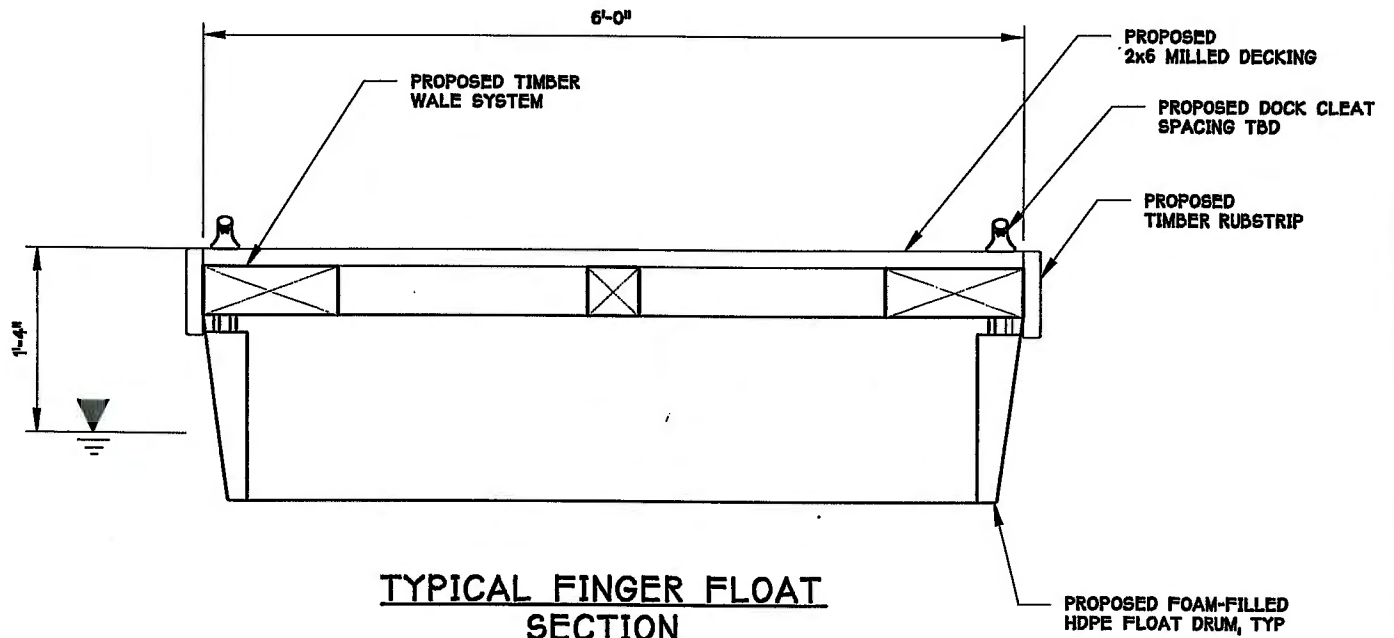

TYPICAL FINGER FLOAT SECTION

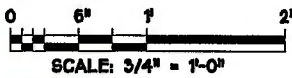

TRANSPAC
MARINAS
P.O. BOX 1169
ANACORTES
WASHINGTON
U.S.A. 98221
(360) 293-8888

AJD
(360) 770-1746

PURPOSE: PROPOSED MARINA REPLACEMENT
APPLICANT:
SNUG HARBOR ASSOCIATES LLC
1897 MITCHELL BAY Rd
SAN JUAN ISLAND, WA 98250
c/o ERIC NELSON
723 HANNA PARK
EDMONDS, WA 98020-2619
IN: MITCHELL BAY
AT: SAN JUAN ISLAND
STATE: WASHINGTON
DATUM: MLLW = 0.0'
LATITUDE: 48.5706808 deg
LONGITUDE: -123.1682217 deg

APPLICATION REFERENCE No:
NWS-2014-966
**SNUG HARBOR MARINA
FINGER FLOAT SECTIONS**

THIS DRAWING IS THE PROPERTY OF AND CONTAINS INFORMATION WHICH BELONGS TO TRANSPAC MARINAS, INC. IT IS BEING LOANED WITH THE UNDERSTANDING THAT IT MAY NOT BE REPRODUCED OR USED IN ANY WAY THAT WOULD BE INJURIOUS TO TRANSPAC'S INTERESTS. DETAILS MAY BE PROTECTED UNDER ONE OR MORE OF THE FOLLOWING U.S. PATENTS: 4,709,647 - 4,887,854 - 4,940,021 - 5,347,948 - 5,529,012 - 6,450,737